

## Meet your Bugaboo Fox 3

Ontdek jouw Bugaboo Fox 3

Sig hej til din Bugaboo Fox 3

Entdecken Sie den Bugaboo Fox 3

Γνωρίστε το Bugaboo Fox 3 σας

Conoce tu Bugaboo Fox 3

Esittelyssä Bugaboo Fox 3

Découvrez la Bugaboo Fox 3

Ecco il tuo Bugaboo Fox 3

Møt din Bugaboo Fox 3

Poznaj swój Bugaboo Fox 3

Descubra o Bugaboo Fox 3

Познакомьтесь с вашей коляской Bugaboo Fox 3

Spoznajte svoj Bugaboo Fox 3

Säg hej till din Bugaboo Fox 3

Bugaboo Fox 3 ile tanışma

Bugaboo Fox 3 の各部の名前

Bugaboo Fox 3 를 만나 보세요

欢迎使用 Bugaboo Fox 3





## Parts for set-up

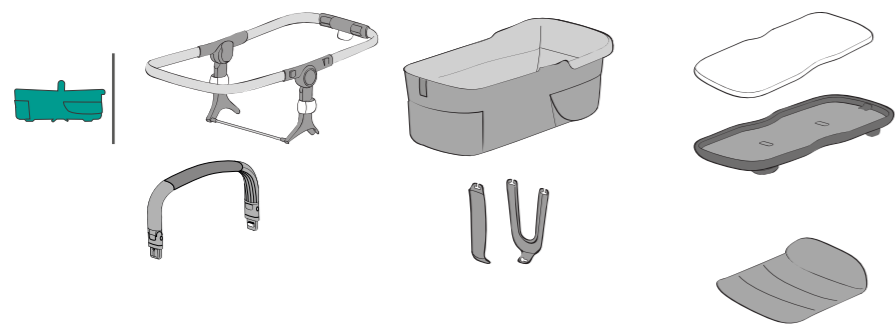
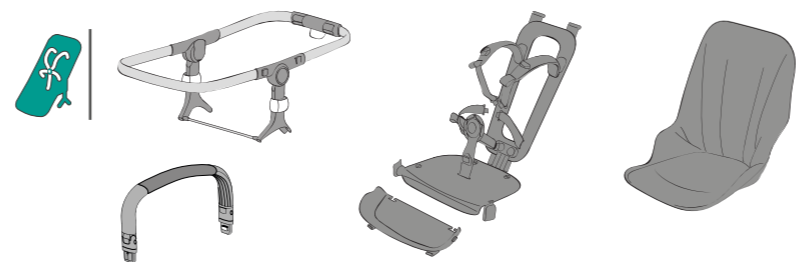
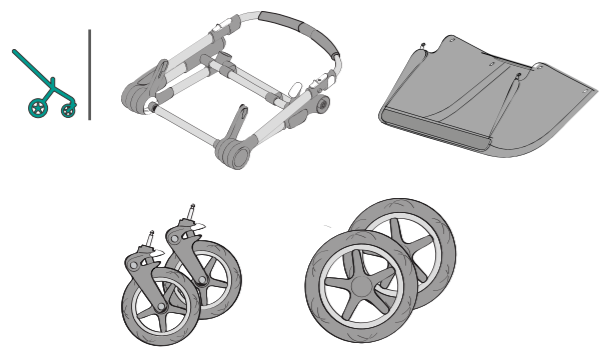

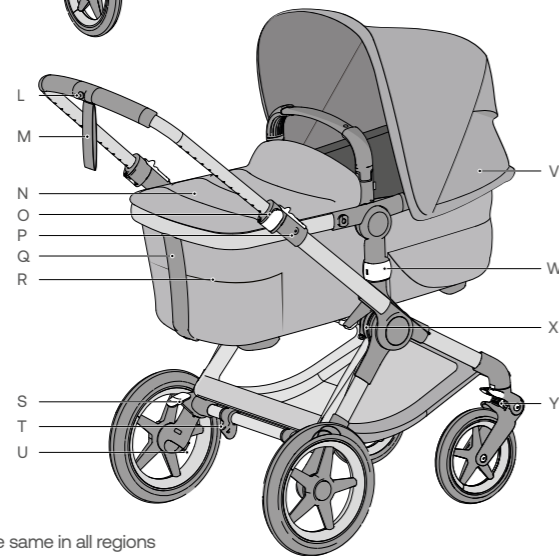
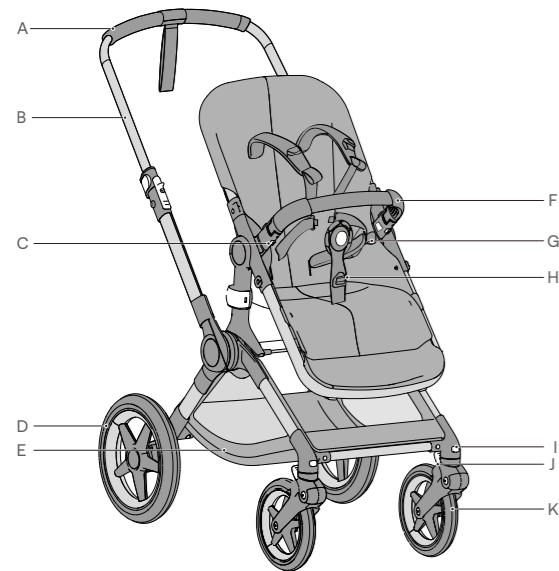

\* Product depicted may not be exactly the same in all regions

<b>EN</b>	A. Handlebar	J. Swivel wheel lock	S. Brake
	B. Chassis	K. Swivel wheel	T. Integrated attachment point 3
	C. Carry handle release button	L. Integrated attachment point 1	U. Large wheel release button
	D. Large wheel	M. Wrist strap	V. Sun canopy
	E. Underseat bag	N. Apron	W. Square white knob
	F. Carry handle	O. Handlebar adjustment clip	X. Unfolding lock
	G. Seat	P. Integrated attachment point 2	Y. Suspension
	H. Harness	Q. Bassinet stiffener	
	I. Swivel wheel release button	R. Bassinet	

<b>CA</b>	A. Handlebar	J. Swivel wheel lock	S. Brake
	B. Chassis	K. Swivel wheel	T. Integrated attachment point 3
	C. Carry handle release button	L. Integrated attachment point 1	U. Large wheel release button
	D. Large wheel	M. Wrist strap	V. Sun canopy
	E. Underseat bag	N. Apron	W. Square white knob
	F. Carry handle	O. Handlebar adjustment clip	X. Unfolding lock
	G. Seat	P. Integrated attachment point 2	Y. Suspension
	H. Harness	Q. Pram body stiffener	
	I. Swivel wheel release button	R. Pram body	

<b>NL</b>	A. Duwbeugel	J. Zwenkwielblokkeerder	T. Bevestigingspunt 3
	B. Onderstel	K. Zwenkwiel	U. Ontgrendelingsknop voor groot wiel
	C. Draagbeugel-ontgrendelingsknop	L. Bevestigingspunt 1	V. Zonnekap
	D. Groot wiel	M. Polsband	W. Vierkante witte knop
	E. Bagagetas	N. Wiegdekje	X. Vergrendeling
	F. Draagbeugel	O. Verstelklampen voor de duwbeugel	Y. Vering
	G. Stoel	P. Bevestigingspunt 2	
	H. Harnas	Q. Versteiger voor wieg	
	I. Ontgrendelingsknop zwenkwielen	R. Wieg	
		S. Rem	

<b>CS</b>	A. Rukojeť	J. Otočný zámek	T. Úchytný bod 3
	B. Podvozek	K. Otočné kolo	U. Tlačítko k uvolnění velkého kola
	C. Tlačítko k uvolnění držadla	L. Úchytný bod 1	V. Stříška kočárku
	D. Velké kolo	M. Popruh na zápěstí	W. Hranatý bílý knoflík
	E. Taška pod sedačku	N. Přenosná taška	X. Odepnutí uzamknutí
	F. Držadlo	O. Svorky pro nastavení rukojeti	Y. Odpružení
	G. Sedačka	P. Úchytný bod 2	
	H. Popruhy	Q. Výztuha hlubokého lůžka	
	I. Tlačítko pro uvolnění otočných kol	R. Příkrývka přenosné tašky	
		S. Výztuha	

<b>DA</b>	A. Styr	I. Knap til frigørelse af styrehjul	R. Lift overdække
	B. Understel	J. Styrehjullås	S. Bremse
	C. Knap til frigørelse af bærehåndtag	K. Svinghjul	T. Påmonteringspunkt 3
	D. Store hjul	L. Påmonteringspunkt 1	U. Udløserknap for store hjul
	E. Taske under sædet	M. Håndledsrem	V. Sommerkaleche
	F. Bærehåndtag	N. Lift	W. Firkantede hvide knapper
	G. Sæde	O. Justeringsclips til styr	X. Udfoldningslås
	H. Seler	P. Påmonteringspunkt 2	Y. Fjedring
		Q. Stiver til lift	

<b>DE</b>	A. Schiebebügel	J. Schwenkverriegelung	R. Liegeaufsatz
	B. Gestell	K. Schwenkrad	S. Bremse
	C. Tragebügel-Entriegelungsknopf	L. Befestigungspunkt 1	T. Befestigungspunkt 3
	D. Großes Rad	M. Sicherheitsriemen für das Handgelenk	U. Entriegelungsknopf des Großen Rades
	E. Untergestell-Tasche	N. Winddecke	V. Sonnendach
	F. Tragebügel	O. Schiebebügel-Einstellclips	W. Quadratischer weißer Knopf
	G. Sitz	P. Befestigungspunkt 2	X. Auseinanderklapp-Sperre
	H. Sicherheitsgurte	Q. Streben für den Liegeaufsatz	Y. Federung
	I. Schwenk-Feststellknopf		

<b>EL</b>	A. Χειρολαβή	J. Ασφάλεια περιστρεφόμενου τροχού	R. Ποδιά πορτ-μπεμπέ (ποδιά καλαθού)
	B. Βάση	K. Περιστρεφόμενος τροχός	S. Φρένο
	C. Μπουτόν απελευθέρωσης χερουλιού μεταφοράς	L. Σημείο στερέωσης 1	T. Σημείο στερέωσης 3
	D. Μεγάλος τροχός	M. Περικάρπιο	U. Κομπι απελευθέρωσης μεγάλου τροχού
	E. Σάκος κάτω από το κάθισμα	N. Πορτ-μπεμπέ (καλάθι)	V. Τέντα ηλίου
	F. Χερουλί μεταφοράς	O. Κλιπ προσαρμογής χειρολαβής	W. Τετράγωνο λευκό μπουτόν
	G. Κάθισμα	P. Σημείο στερέωσης 2	X. Αναδιπλούμενη ασφάλεια
	H. Ζώνη	Q. Ενισχυτικό έλασμα πορτ-μπεμπέ	Y. Ανάρτηση
	I. Κομπι απελευθέρωσης περιστρεφόμενου τροχού		

<b>ES</b>	A. Manillar	I. Botón de desenganche de rueda giratoria	Q. Lengüeta del capazo
	B. Chasis	J. Bloqueo de ruedas giratorias	R. Cubrepies
	C. Botón de apertura del asa de transporte	K. Rueda giratoria	S. Freno
	D. Rueda grande	L. Punto de enganche 1	T. Punto de enganche 3
	E. Cesta de compras	M. Muñequera de seguridad	U. Botón de desenganche de las ruedas grandes
	F. Asa de transporte	N. Capazo	V. Capota
	G. Silla	O. Abrazaderas del manillar extensible	W. Boton cuadrado blanco
	H. Arnés	P. Punto de enganche 2	X. Seguro de desplegado
			Y. Suspensión

<b>FI</b>	A. Työntöaisa	I. Kääntyvien pyörien vapautusnäppäin	Q. Vaunukopan jäykistin
	B. Runko	J. Kääntyvien pyörien lukko	R. Vaunukopan peite
	C. Kantokahvan vapautupainike	K. Kääntyvä pyörä	S. Jarru
	D. Isot pyörät	L. Kiinnityskohta 1	T. Kiinnityskohta 3
	E. Istuinkori	M. Käsilenkki	U. Ison pyörän vapautusnäppäin
	F. Kantokahva	N. Vaunukoppa	V. Suojakuomu
	G. Istuin	O. Työntöaisan säätökiinnittimet	W. Neliskulmainen valkoinen nappi
	H. Valjaat	P. Kiinnityskohta 2	X. Avaussalpa
			Y. Jousitus

## FR

A. Guidon	roue pivotante	R. Tablier de nacelle
B. Châssis	J. Bouton de verrouillage de la roue pivotante	S. Frein
C. Bouton de déverrouillage de la poignée	K. Roue pivotante	T. Point de fixation 3
D. Grosse roue	L. Point de fixation 1	U. Bouton de déverrouillage de la grosse roue
E. Panier	M. Dragonne de poignet	V. Capote
F. Poignée	N. Nacelle	W. Boutons blancs carrés
G. Siège	O. Clips d'ajustement du guidon	X. Bouton de dépliage
H. Harnais	P. Point de fixation 2	Y. Suspension
I. Bouton de déverrouillage de la	Q. Armature de la nacelle	

## IT

A. Manubrio	J. Blocco ruote piroettanti	R. Coperta navetta
B. Telaio	K. Ruota piroettante	S. Freno
C. Pulsante di rilascio manubrio	L. Punto di installazione 1	T. Punto di installazione 3
D. Ruota grande	M. Cinghia da polso	U. Pulsante di sblocco della ruota grande
E. Borsa portaoggetti	N. Navetta	V. Capottina
F. Manico	O. Clip per la regolazione del manubrio	W. Pulsanti quadrati bianchi
G. Seggiolino	P. Punto di installazione 2	X. Blocco di apertura
H. Cintura di sicurezza	Q. Elementi di rinforzo della navicella	Y. Molleggio
I. Pulsante di sblocco ruote piroettanti		

## NO

A. Styre	J. Retningslås for svinghjul	T. Festepunkt 3
B. Understell	K. Svinghjul	U. Frigjøringsknapp for store hjul
C. Utløsningsknapp for bærehåndtak	L. Festepunkt 1	V. Kalesje
D. Stort hjul	M. Håndleddbånd	W. Firkantet hvit knapp
E. Bagasjeveske	N. Bag	X. Felle opp lås
F. Bærehåndtak	O. Justeringsklips for styre	Y. Fjæring
G. Sete	P. Festepunkt 2	
H. Sele	Q. Bagavstiver	
I. Retningslås for svinghjul	R. Overtrekk	
	S. Bremse	

## PL

A. Rączka	K. Koło zwrotne	U. Przycisk do zwalniania dużych kół
B. Podwozie	L. Miejsce przyłączenia 1	V. Budka przeciwsłoneczna
C. Przycisk do zwalniania rączki	M. Pasek na nadgarstek	W. Kwadratowy biały przycisk
D. Duże koło	N. Gondola	X. Blokada rozkładania
E. Torba pod siedzenie	O. Klamry do regulacji rączki	Y. Zawieszenie
F. Rączka do przenoszenia	P. Miejsce przyłączenia 2	
G. Siedzenie	Q. Usztywniacz gondoli	
H. Szelki	R. Przykrycie gondoli	
I. Przycisk do kół zwrotnych	S. Hamulec	
J. Zamek zwrotny	T. Miejsce przyłączenia 3	

## PT

A. Manípulo	giratórias	Q. Reforço da alcofa
B. Chassis	J. Bloqueador das rodas giratórias	R. Alcofa
C. Botão de desengate da asa de transporte	K. Roda giratória	S. Travão
D. Roda grande	L. Ponto de fixação 1	T. Ponto de fixação 3
E. Cesto	M. Pulseira de segurança	U. Botão de libertação da roda grande
F. Asa de transporte	N. Cobre-pés da alcofa	V. Capota
G. Cadeira	O. Peças de fixação de regulação do manípulo	W. Botão quadrado branco
H. Cinto de segurança	P. Ponto de fixação 2	X. Bloqueio de desdobramento
I. Botão para remoção das rodas		Y. Suspensão

## RU

A. Ручка	поворотного колеса	R. Фартук
B. Шасси	J. Замок поворотного колеса	S. Тормоз
C. Кнопка разблокирования ручки для переноски	K. Поворотное колесо	T. Точка крепления 3
D. Большое колесо	L. Точка крепления 1	U. Кнопка разблокирования большого колеса
E. Сумка под сиденьем	M. Ремешок на запястье	V. Капюшон
F. Ручка для переноски	N. Люлька	W. Квадратная белая ручка
G. Сиденье	O. Регулирующий зажим ручки	X. Блокировка раскладывания
H. Ремни безопасности	P. Точка крепления 2	Y. Подвеска
I. Кнопка разблокирования	Q. Укрепляющие элементы люльки	

## SL

A. Krmilo	J. Zaklep vrtljivih koles	S. Zavora
B. Podvozje	K. Vrtljivo kolo	T. Pritrdilna točka 3
C. Gumb za sprostitev ročaja	L. Pritrdilna točka 1	U. Gumb za sprostitev velikih koles
D. Veliko kolo	M. Zapestni trak	V. Strešica
E. Torba pod sedežem	N. Košara za otroka	W. Štirioglat bel gumb
F. Ročaj	O. Objemke za prilagoditev krmila	X. Zložljivi zaklep
G. Sedež	P. Pritrdilna točka 2	Y. Vzmetenje
H. Jermen	Q. Ojačevalnik za košaro za otroka	
I. Gumb za sprostitev vrtljivih koles	R. Pregrinjalo košare za otroka	

## SV

A. Styre	J. Swivellås	T. Fästpunkt 3
B. Chassi	K. Svivelhjul	U. Frigöringsknapp för stora hjul
C. Bärhandtagets frigöringsknapp	L. Fästpunkt 1	V. Sufflett
D. Stora hjul	M. Handledsband	W. Fyrkantigt vit knapp
E. Varukorg	N. Liggdel	X. Fälla upp lås
F. Bärhandtag	O. Justeringsklämmor till styret	Y. Fjädring
G. Sittdel	P. Fästpunkt 2	
H. Sele	Q. Inlägg för liggdel	
I. Frigöringsknapp till swivelhjul	R. Liggdelslock	
	S. Broms	

## TR

A. Tutma Kolu	Düğmesi	S. Fren
B. Şasi	J. Döner Kilit	T. Bağlantı Noktası 3
C. Taşıma Kolu Serbest Bırakma Düğmesi	K. Döner Tekerlek	U. Geniş Tekerleği Serbest Bırakma Düğmesi
D. Geniş Tekerlek	L. Bağlantı Noktası 1	V. Güneş Gölgeliği
E. Koltuk Altı Çantası	M. Bilek Kayışı	W. Kare Beyaz Buton
F. Taşıma Kolu	N. Beşik	X. Açılır Kilit
G. Koltuk	O. Tutma Kolu Ayarlama Klipsleri	Y. Süspansiyon
H. Koşum Takımı	P. Bağlantı Noktası 2	
I. Döner Tekerlek Serbest Bırakma	Q. Beşik Destek Parçası	
	R. Önlük	

## JA

A. ハンドルバー	J. 旋回ロック	T. 接続点 3
B. 本体	K. 旋回式ホイール	U. ラージホイール解除ボタン
C. キャリヤハンドルレバー解除ボタン	L. 接続点 1	V. サンキャノピー
D. ラージホイール	M. リストストラップ	W. 白角ボタン
E. アンダーシートバッグ	N. バシネット	X. 展開ロック
F. キャリヤハンドル	O. ハンドルバー調整クリップ	Y. サスペンション
G. シート	P. 接続点 2	
H. 安全ベルト	Q. キャリヤコット補強具	
I. 旋回式ホイール解除ボタン	R. バシネットエプロン	
	S. ストッパー	

## KO

A. 핸들바	K. 회전 바퀴	U. 대형 바퀴 해제 버튼
B. 새시	L. 액세서리 장착포인트1	V. 선 캐노피
C. 캐리 핸들 해제 버튼	M. 손목 스트랩	W. 흰색 사각 버튼
D. 대형 바퀴	N. 배시넷	X. 잠금/해제 장치
E. 언더시트 바스켓	O. 핸들바 조절 클립	Y. 서스펜션
F. 회전식 캐리 핸들	P. 액세서리 장착포인트2	
G. 시트	Q. 배시넷 스티프너	
H. 안전 벨트	R. 배시넷 커버	
I. 회전 바퀴 해제 버튼	S. 브레이크	
J. 회전 바퀴 잠금 장치	T. 액세서리 장착포인트3	

## ZH

A. 手把管	K. 转向轮	U. 大轮胎释放按钮
B. 车架	L. 连接点 1	V. 遮阳篷
C. 前扶手释放按钮	M. 手把织带	W. 白色方形按钮
D. 大轮胎	N. 提篮	X. 展开锁
E. 购物袋	O. 手把管调节扣	Y. 悬架
F. 前扶手	P. 连接点 2	
G. 座椅	Q. 提篮布加强杆	
H. 安全带	R. 脚罩	
I. 转向轮释放按钮	S. 刹车	
J. 转向锁	T. 连接点 3	

## Instructions - visual language



Visual check OK  
Afbeelding controle OK  
Vizuální kontrola OK  
Visuel kontrol OK  
Optische Kontrolle OK  
Comprobación visual correcta  
Οπτικός έλεγχος OK  
Silmävarainen tarkistus OK

Contrôle visuel OK  
Esito positivo del controllo visivo  
Visuell kontroll OK  
Kontrola wzrokowa OK  
Verificação visual OK  
Наружный осмотр не выявил неисправностей

Znak 'pravilno'  
Visuell kontroll OK  
Görsel kontrol tamam  
目視点検 OK  
올바름  
正确的效果



Visual check wrong  
Afbeelding controle niet goed  
Vizuální kontrola - špatně  
Visuel kontrol ikke korrekt  
Optische Kontrolle falsch  
Comprobación visual incorrecta  
Οπτικός έλεγχος λάθος  
Silmävarainen tarkastus ei

hyväksyttävä  
Contrôle visuel erreur  
Esito negativo del controllo visivo  
Visuell kontroll feil  
Kontrola wzrokowa negatywna  
Verificação visual errada  
Наружный осмотр выявил

неисправность  
Znak 'napačno'  
Visuell kontroll fel  
Görsel kontrol yanlış  
目視点検間違い  
올바르지 않음  
错误的效果



Audible click  
Hoorbare klik  
Slyšitelné cvaknutí  
Tydelig kliklyd  
Hörbares Klickgeräusch  
Clic sonoro  
Ηχητικό κλικ

Kuulet naksahduksen  
Clic audible  
Scatto (clic)  
Hörbart klick  
Slychać kliknięcie  
Clique audible  
Слышимый щелчок

Zvočni klik  
Hörbart klickande ljud  
Duyulabilir klik sesi  
聞き取れるクリック音  
찰칵 소리가 들림  
"咔嚓"声



Movement in the indicated direction  
Beweging in de aangegeven richting  
Pohyb v uvedeném směru  
Bevægelse i den indikerede retning  
Bewegung in der angegebenen Richtung  
Κίνηση προς την κατεύθυνση που υποδεικνύεται

Movimiento en la dirección indicada  
Liike osoitettuun suuntaan  
Mouvement dans le sens indiqué  
Spostamento nella direzione indicata  
Bevegelse i indikert retning  
Ruch we wskazanym kierunku  
Movimento na direção indicada

движение в указанном направлении  
Premik v označeno smer  
Rörelse i angiven riktning  
Gösterilen yönde hareket  
矢印の方向への動作  
표시된 방향으로 이동  
按照所示方向运动



Video Available  
Video Beschikbaar  
K Dispozici Je Video  
Video Tilgjengelig  
Video verfügbar  
Διατίθεται Video  
Vidéo Disponible

Video Saatavissa  
Vidéo Disponible  
Video Disponibile  
Video Tilgjengelig  
Video Dostępne  
Vidéo Disponível  
Видео

Video Na Vojo  
Video Tilgjenglig  
Video Mevcut  
ビデオをご覧ください  
비디오 가이드  
提供视频



When you see this symbol in the instructional part of the user guide, please refer to the warnings chapter for ensuring the safe use of the Bugaboo Fox 3.

Wanneer je op de instructiepagina's in de gebruiksaanwijzing dit symbool ziet, raadpleeg dan het hoofdstuk met waarschuwingen om er zeker van te zijn dat je de Bugaboo Fox 3 veilig gebruikt.

Pokud uvidíte v instruktažní části uživatelské příručky tento symbol, podívejte se do kapitoly varování, abyste si ověřili bezpečné používání kočárku Bugaboo Fox 3.

Når du ser dette symbol i instruktionsdelen af brugervejledningen, skal du bladere om til afsnittet om advarsler for at sikre, at du anvender Bugaboo Fox 3 korrekt.

Wenn Sie dieses Symbol in der Bedienungsanleitung sehen, lesen Sie bitte den Abschnitt mit den Warnhinweisen, um die sichere Nutzung des Bugaboo Fox 3 sicherzustellen.

Όταν βλέπετε αυτό το σύμβολο στο τμήμα οδηγιών των οδηγιών χρήσης, παρακαλούμε ανατρέξτε στο κεφάλαιο προειδοποιήσεων για τη διασφάλιση της ασφαλούς χρήσης του Bugaboo Fox 3.

Quando veas este símbolo en las instrucciones de la guía del usuario, consulta el capítulo de advertencias para garantizar un uso seguro del Bugaboo Fox 3.

Tämä symboli ilmaisee käyttöoppaan ohjeosassa vaaraa. Katso lisätietoja varoituksia sisäitävistä luvusta ja varmista, että käytät Bugaboo Fox 3 turvallisesti.

Lorsque vous apercevez ce symbole dans les instructions du mode d'emploi, veuillez vous référer au chapitre sur les avertissements pour garantir une utilisation en toute sécurité de la Bugaboo Fox 3.

Quando vedi questo simbolo nelle istruzioni della guida all'uso, fai riferimento al capitolo relativo alle avvertenze per informazioni su come usare Bugaboo Fox 3 in modo sicuro.

Når du ser dette symbolet i instruksjonsdelen av bruksanvisningen, kan du se kapitlet om advarsler for å sikre at du bruker Bugaboo Fox 3 på en trygg måte.

Jesli widzisz ten symbol w instruktażowej części przewodnika, przejdź do rozdziału z ostrzeżeniami. Dzięki temu zyskasz pewność, że korzystasz z wózka Bugaboo Fox 3 w bezpieczny sposób.

Quando vir este símbolo nas instruções do guia do utilizador, consulte o capítulo de avisos para garantir que utiliza o Bugaboo Fox 3 de uma forma segura.

Когда вы увидите этот символ в инструкционной части руководства пользователя, см. главу с предупреждениями, чтобы обеспечить безопасное использование коляски Bugaboo Fox 3.

Če v navodilih v priročniku za uporabnike vidite ta znak, preberite poglavje z opozorili, kjer so navodila za varno uporabo vozička Bugaboo Fox 3.

Om du ser den här symbolen i anvisningarna i användarhandboken ska du titta i varningskapitlet så att du använder Bugaboo Fox 3 säkert.

Kullanıcı klavuzunun açıklamalar kısmında bu simgeyi gördüğünüzde, Bugaboo Fox 3'in güvenli kullanımını sağlamak için, lütfen uyarılar bölümüne başvurun.

このシンボルがユーザーガイドの使用手順に表示されている場合は、バガブー フォックス 3を安全にご使用いただくための警告ページを参照してください。

사용설명서에 이 기호가 표시되어 있는 경우, Bugaboo Fox 3의 안전한 사용을 위해 경고 챕터를 참조하십시오.

当您在本说明书的指导说明部分看到这一符号时，请参阅警告章节，确保您将安全使用 Bugaboo Fox 3。

## White parts

All the white parts of your Bugaboo Fox 3 are functional. They're the parts that allow you to adapt and change your Bugaboo Fox 3.

Alle witte onderdelen van uw Bugaboo Fox 3 hebben een functie. Dit zijn de onderdelen waarmee u uw Bugaboo Fox 3 kunt verstellen en veranderen.

Všechny bílé části vašeho Bugaboo Fox 3 jsou funkční. Jsou to části, které vám umožňují přizpůsobit a změnit váš Bugaboo Fox 3.

Alle de hvide dele på din Bugaboo Fox 3 er funktionelle. Det er disse dele, der gør det muligt for dig at tilpasse og ændre din Bugaboo Fox 3.

Alle weißen Teile Ihres Bugaboo Fox 3 haben spezielle Funktionen/sind funktionell. Das heißt: Mit diesen Teilen können Sie Ihren Bugaboo Fox 3 einstellen und verändern.

Όλα τα λευκά μέρη του Bugaboo Fox 3 είναι λειτουργικά. Είναι τα μέρη που σας επιτρέπουν να προσαρμόσετε και να αλλάξετε το Bugaboo Fox 3 σας.

Todas las piezas blancas de su Bugaboo Fox 3 son funcionales. Son las piezas que le permiten adaptar y cambiar su Bugaboo Fox 3.

Kaikki valkoiset osat ovat toiminnallisia Bugaboo Fox 3 -vaunuissa. Ne ovat osia, joiden voit sovittaa ja muunnella Bugaboo Fox 3 -lastenvaunuja.

Toutes les parties blanches de votre Bugaboo Fox 3 sont fonctionnelles. Ces parties vous permettent d'adapter et de modifier votre Bugaboo Fox 3 selon vos besoins.

Tutte le parti bianche del Bugaboo Fox 3 sono funzionali. Questi pezzi consentono di adattare e modificare il Bugaboo Fox 3.

Alle de hvite delene på din Bugaboo Fox 3 er funksjonelle. Det er deler som gjør det mulig for deg å tilpasse og endre din Bugaboo Fox 3.

Wszystkie białe części Bugaboo Fox 3 są funkcjonalne. Są to części umożliwiające adaptowanie i modyfikowanie Bugaboo Fox 3.

Todas as partes brancas do seu Bugaboo Fox 3 são funcionais. São as partes que lhe permitem adaptar e mudar o seu Bugaboo Fox 3.

Все функциональные детали коляски Bugaboo Fox 3 выделены белым цветом. Эти детали позволяют трансформировать коляску Bugaboo Fox 3.

Vsi beli deli vašega vozička Bugaboo Fox 3 so funkcionalni. To so deli, ki vam omogočajo, da prilagodite in spremenite vaš voziček Bugaboo Fox 3.

Alla vita delar på din Bugaboo Fox 3 är funktionsdelar. Dessa delar gör att du kan anpassa och ändra din Bugaboo Fox 3.





Bugaboo Fox 3 ürününüzün tüm beyaz parçaları işlevseldir. Bunlar Bugaboo Fox 3 ürününüzü ayarlamanızı ve değiştirmenizi sağlayan parçalardır.

バガブー フォックス 3の白いパーツがすべて機能することを確認してください。白いパーツを使用してバガブー フォックス 3を調整および変更します。



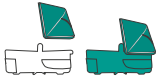
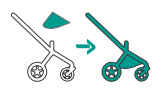



Bugaboo Fox 3의 흰색 부품은 모두 기능이 있는 부분으로, 스톱러를 조작할 때 사용됩니다.





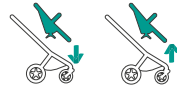



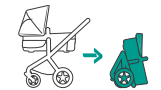
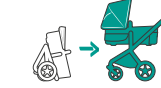

Bugaboo Fox 3的所有白色部件均为功能部件。这些部件能够让你调整和变化您的 Bugaboo Fox 3。

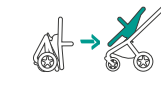
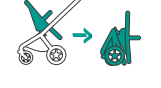
## Set-up

	..... 16		..... 23
	..... 18		..... 25
	..... 19		..... 29

## Features

	..... 32
	..... 33
	..... 34
	..... 37
	..... 39
	..... 41
	..... 42
	..... 43

	..... 44
	..... 46
	..... 47
	..... 49
	..... 50
	..... 52
	..... 53
	..... 54
	..... 55
	..... 56
	..... 57
	..... 60

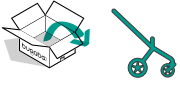

www.bugaboo.com/support/bugaboo-fox

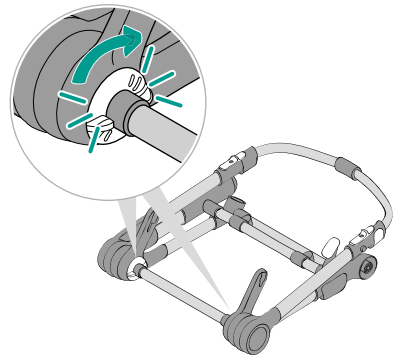
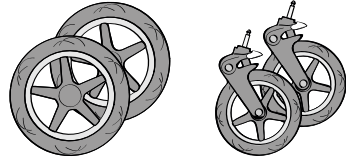
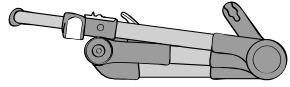

1 .....

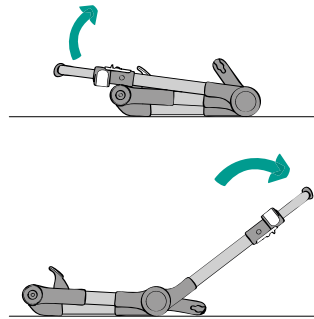

2 .....

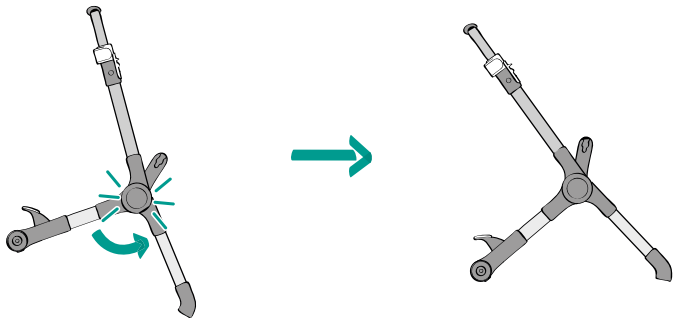

3 .....

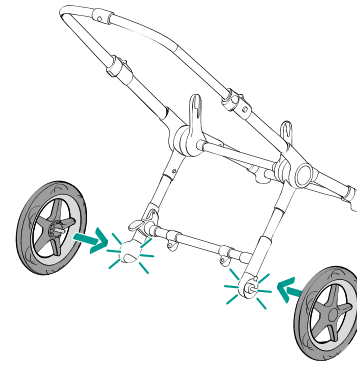

4 .....

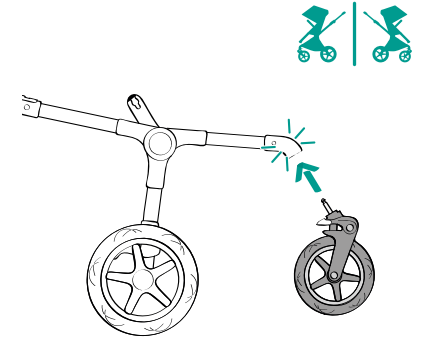

5 .....

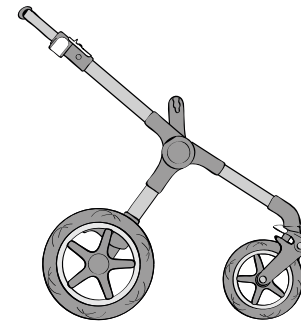

.....

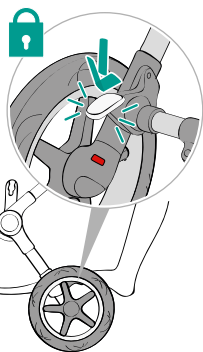
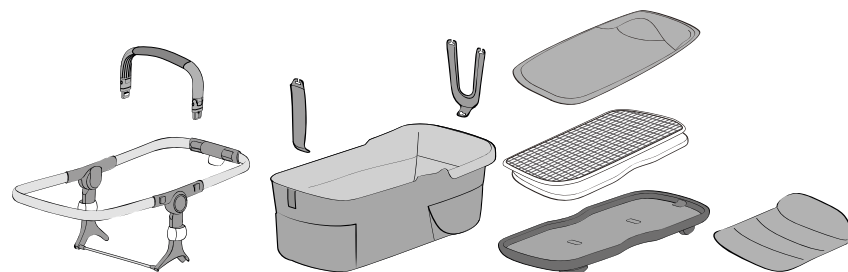
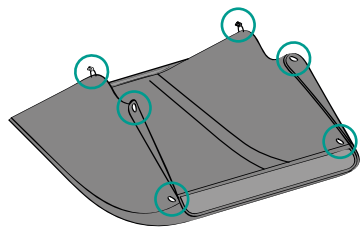
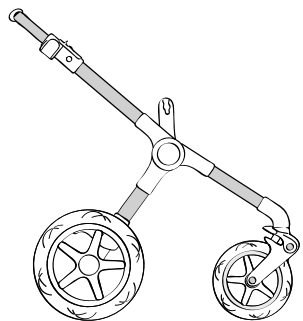

1

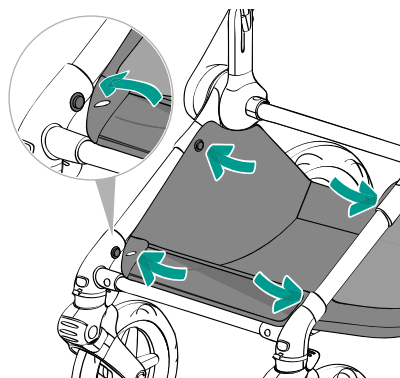

2

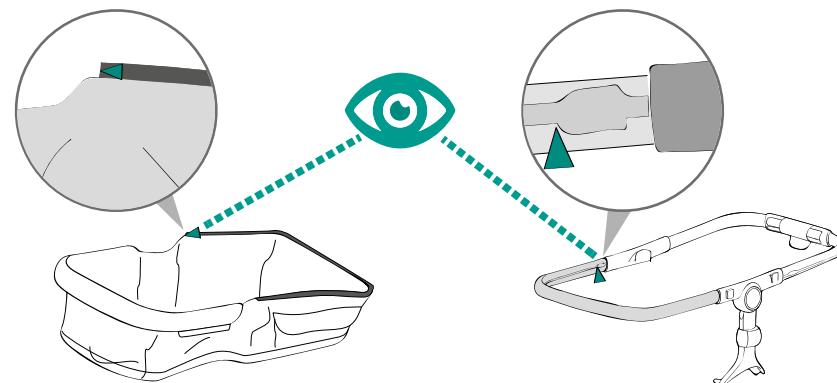

1

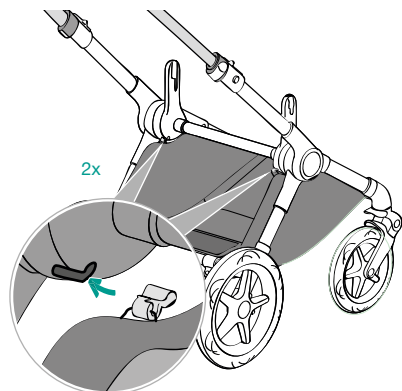

3

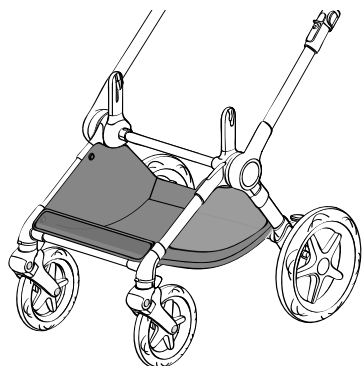

4

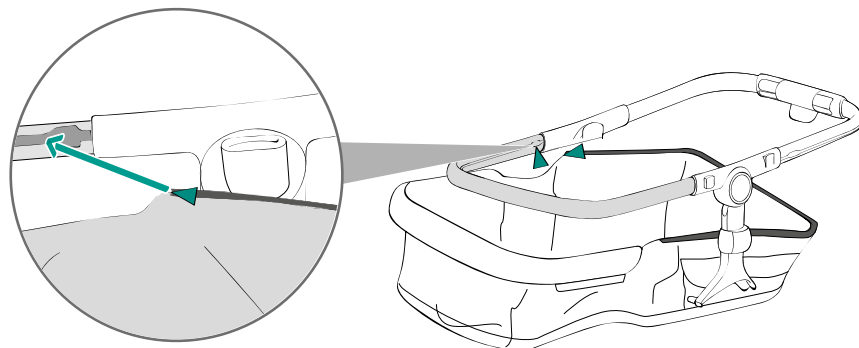

2

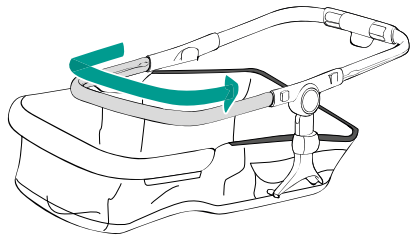

3

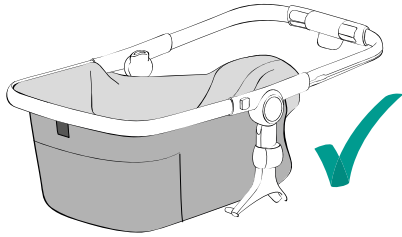

4

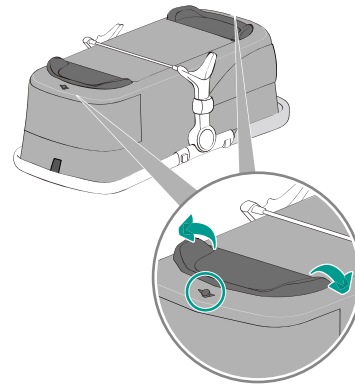

8

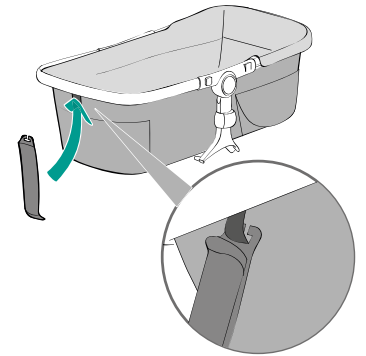

9

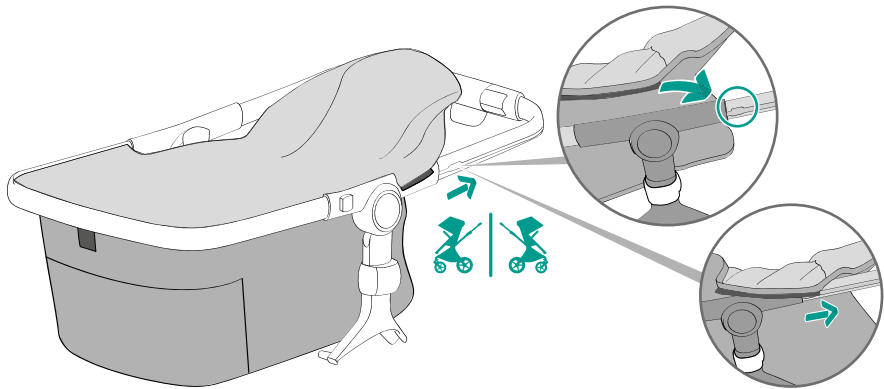

5

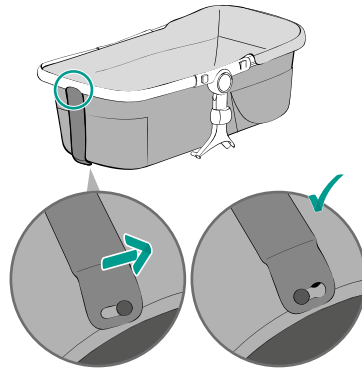

10

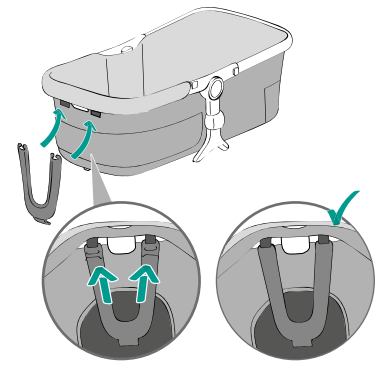

11

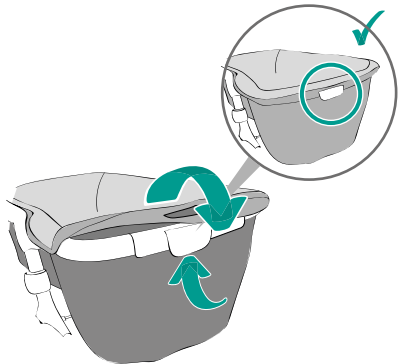

6

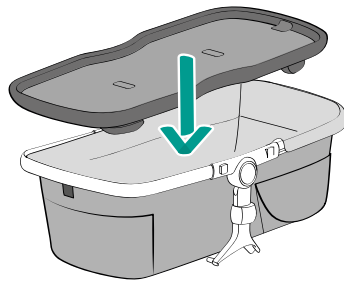

7

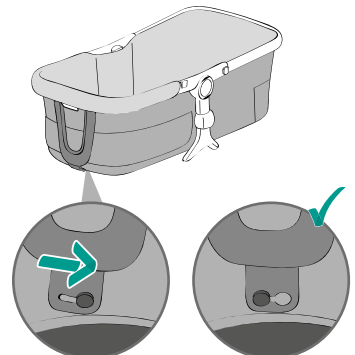

12

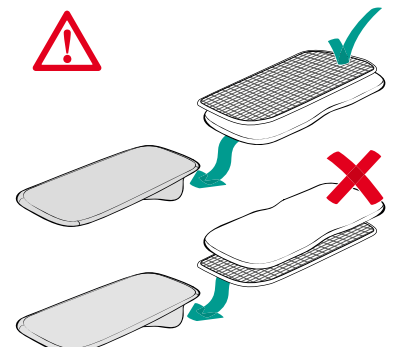

13

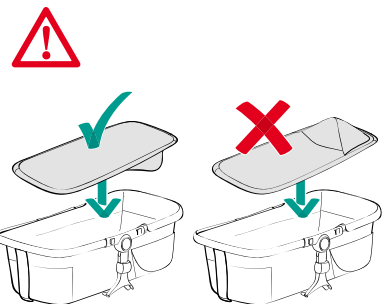
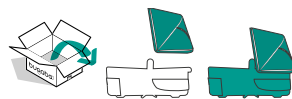

14

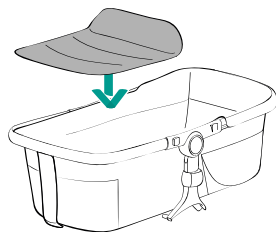

15

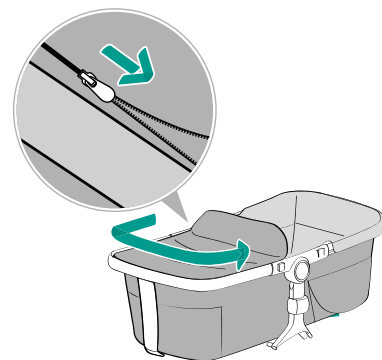
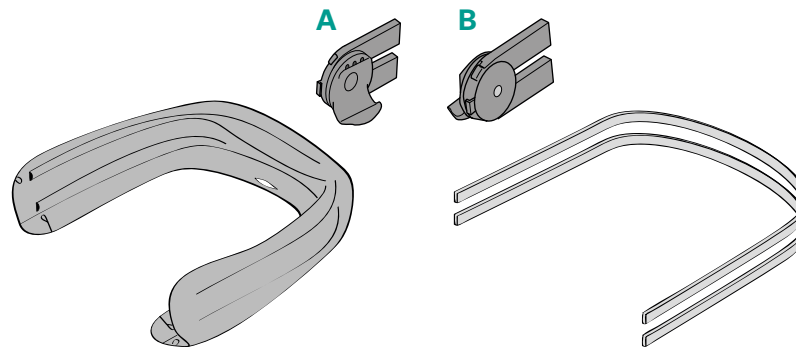

16

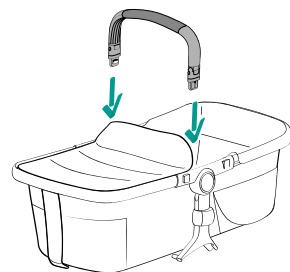

17

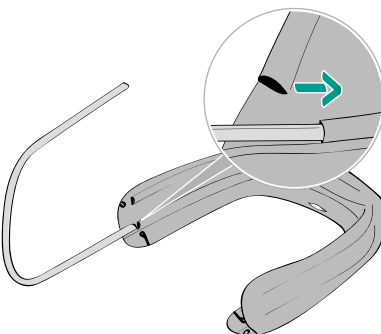

1

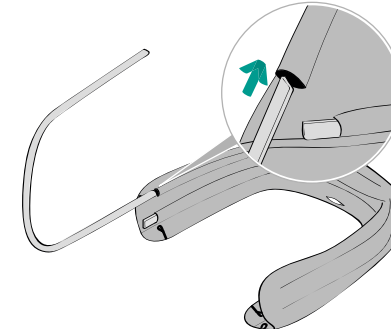

2

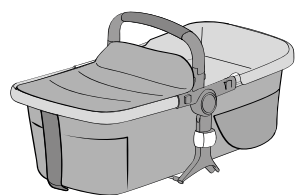

22

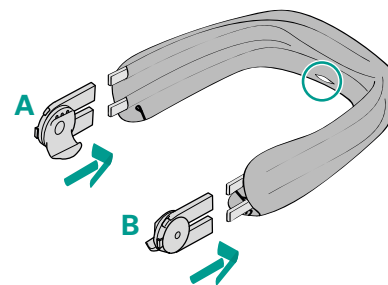
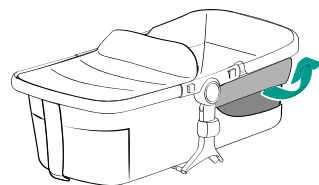

3

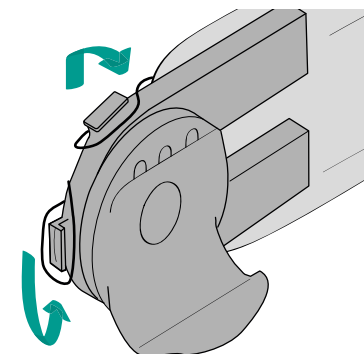

4

23

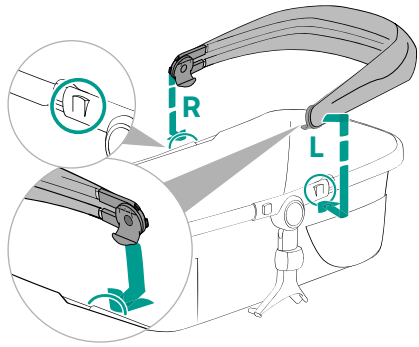

5

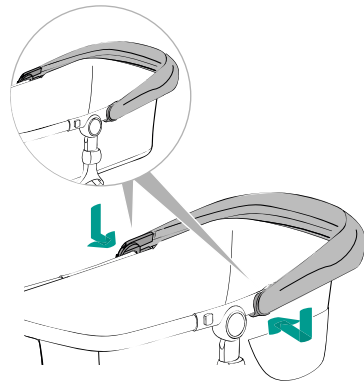

6

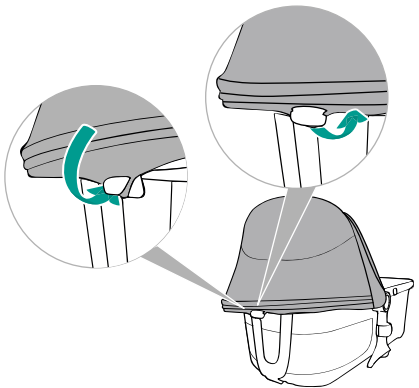
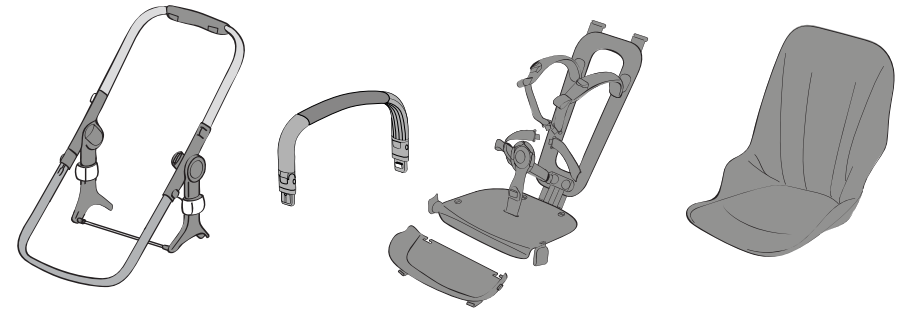

7

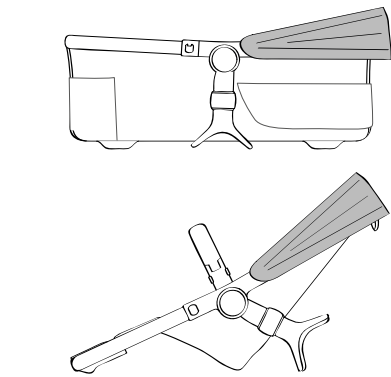

8

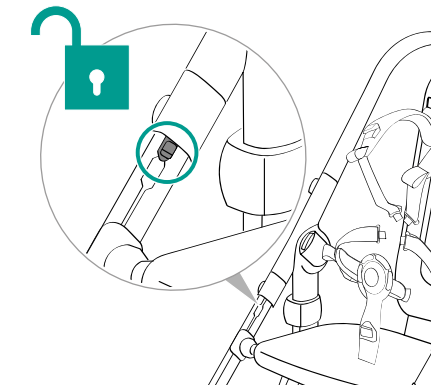

1

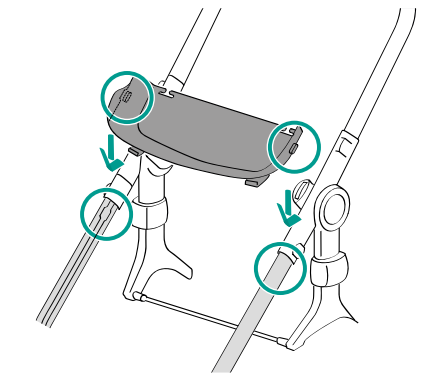

2

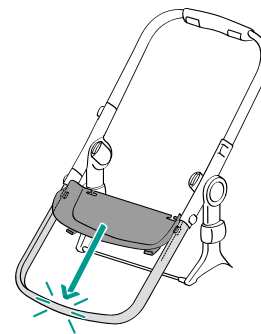

3

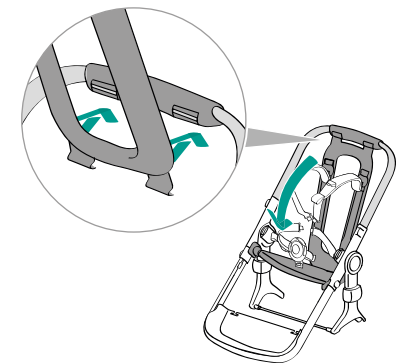

4

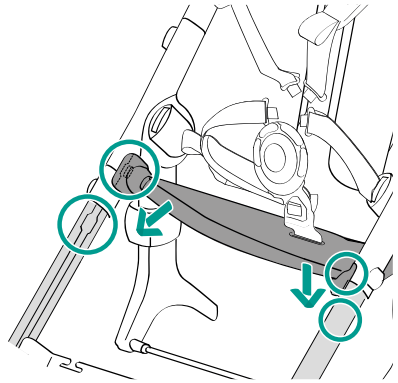

5 .....

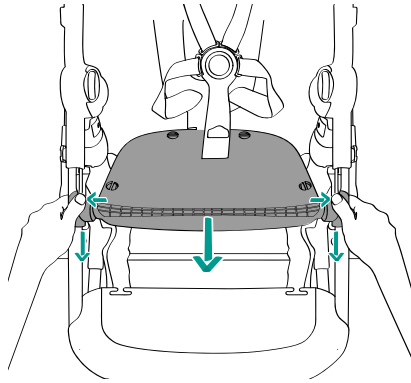

6 .....

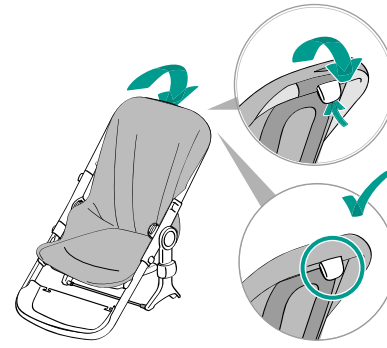

11 .....

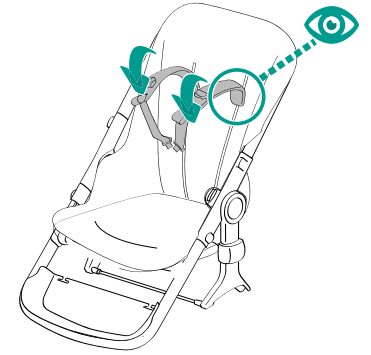

12 .....

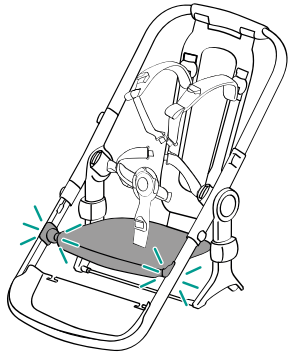

7 .....

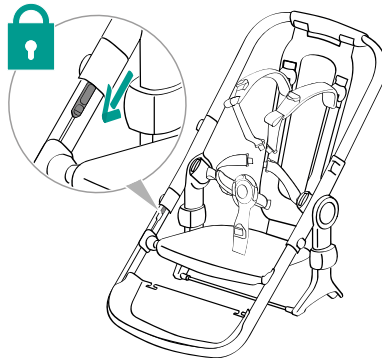

8 .....

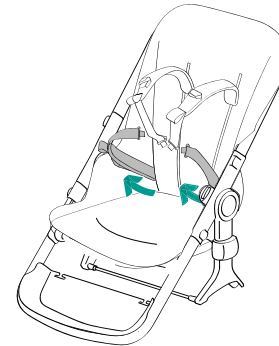

13 .....

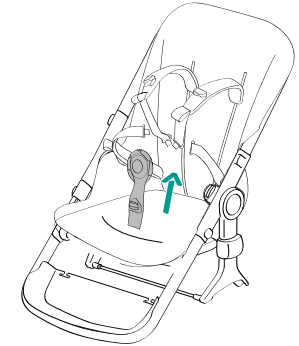

14 .....

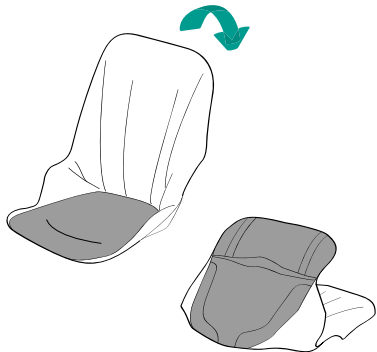

9 .....

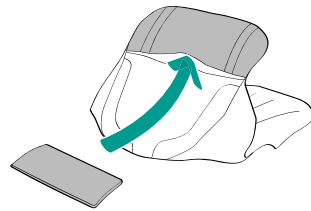

10 .....

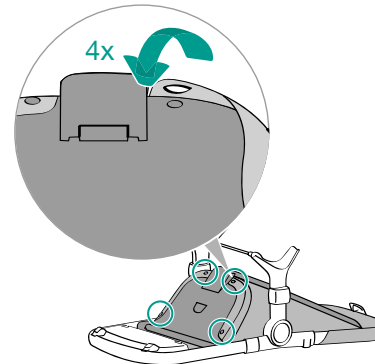

15 .....

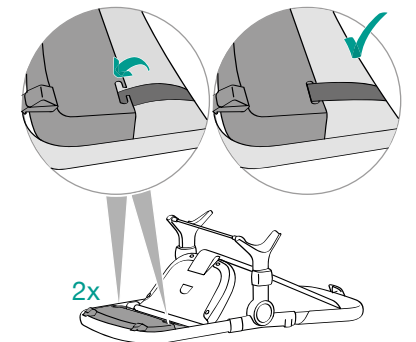

16 .....

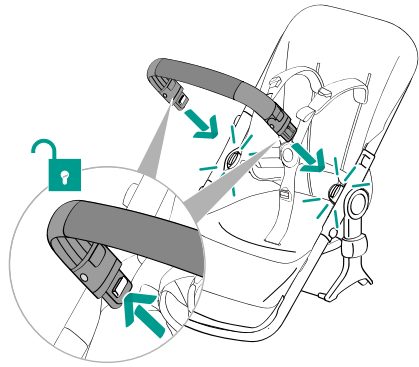

17



18

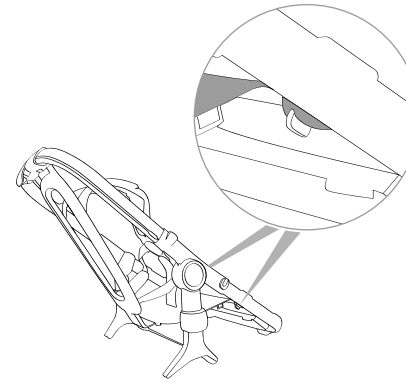

1

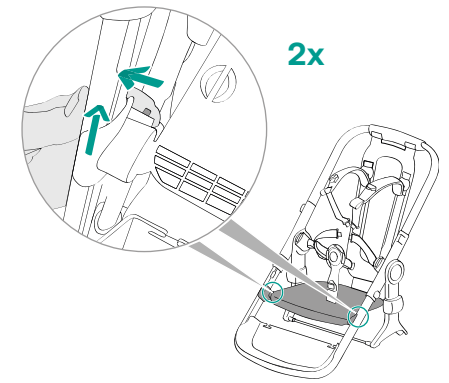

2

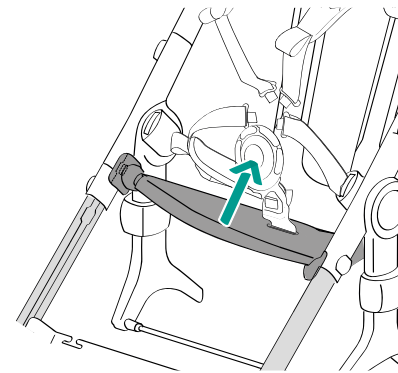

3

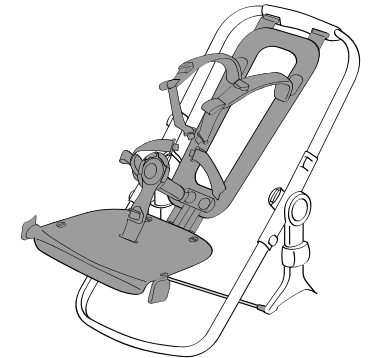

4

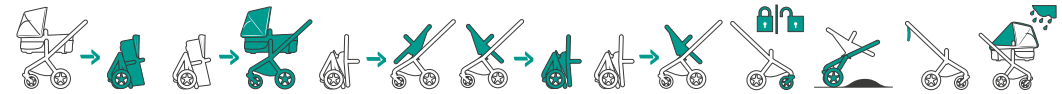
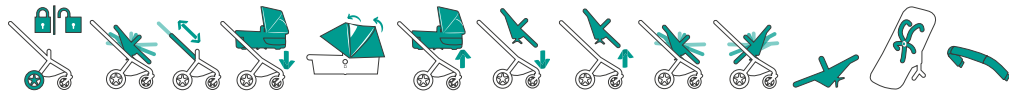

## Features

Please pay extra attention to all the features of the Bugaboo Fox 3. This enables you to use this product to the fullest and secures a smooth ride for you and your child.

Lees de informatie over alle kenmerken van de Bugaboo Fox 3 goed door. Zo gebruik je dit product optimaal en ben je verzekerd van een soepele rit voor jou en je kind.

Věnujte prosím speciální pozornost všem funkcím kočárku Bugaboo Fox 3. To vám umožní využívat tento výrobek naplno a zajistí plynulou jízdu vám i Vašemu dítěti.

Vær ekstra opmærksom på de mange funktioner, som Bugaboo Fox 3 har. På denne måde får du størst mulig glæde af produktet, og du sikrer en god oplevelse for dig selv og dit barn.

Bitte informiere dich eingehend über alle Produkteigenschaften des Bugaboo Fox 3. So ist sichergestellt, dass du ihn optimal benutzt, damit du mit deinem Kind ein ruhiges Fahrerlebnis genießt.

Δώστε ιδιαίτερη προσοχή σε όλα τα χαρακτηριστικά του Bugaboo Fox 3. Αυτό θα σας επιτρέψει να χρησιμοποιήσετε το προϊόν στο έπακρο και διασφαλίζει μια ομαλή βόλτα για εσάς και το παιδί σας.

Por favor, presta especial atención a todas las características del Bugaboo Fox 3. Esto te permitirá sacar el máximo partido a este producto y te garantizará el paseo más suave para ti y para tu hijo.

Kiinnitä erityishuomiota kaikkein Bugaboo Fox 3 in ominaisuuksiin. Niin voit hyödyntää tätä tuotetta kaikin mahdollisin tavoin ja varmistaa tasaisen ajon itsellesi ja lapsellesi.

Veillez prêter une attention particulière à toutes les caractéristiques de la Bugaboo Fox 3. Cela vous permettra d'utiliser ce produit au maximum de ses capacités et d'assurer une conduite agréable pour vous et votre enfant.

Si prega di prestare particolare attenzione a tutte le caratteristiche di Bugaboo Fox 3. Questo consente di sfruttare appieno le funzioni del prodotto oltre ad assicurare una passeggiata in sicurezza a te e al tuo bambino.

Vær ekstra oppmerksom på alle funksjonene til Bugaboo Fox 3. Dette lar deg bruke produktet best mulig, og du sikrer en god opplevelse både for deg og barnet ditt.

Prosimy zwrócić szczególną uwagę na wszystkie funkcje Bugaboo Fox 3. Umożliwi to pełne wykorzystanie produktu i zapewni płynną jazdę Tobie i Twojemu dziecku.

Por favor preste atenção redobrada a todas as características do Bugaboo Fox 3. Isto permite-lhe usar este produto no seu máximo potencial e assegura uma viagem suave para si e o seu filho.

Внимательно изучите все функции коляски Bugaboo Fox 3, чтобы по-максимуму использовать все ее возможности и получать удовольствие от прогулок с ребенком.

Pozorno si oglejte vse funkcije vozička Bugaboo Fox 3. Tako boste lahko izkoristili vse njegove prednosti in poskrbeli, da bo uporaba vozička prijetna tako za vas kot za otroka.

Vänligen läs noggrant igenom informationen om Bugaboo Fox 3 funktioner, så att du kan använda produkten på bästa sätt och att skapa trygga, smidiga åkture för dig och ditt barn.

Lütfen Bugaboo Fox 3'in tüm özelliklerine çok dikkat edin. Bu, üründen en iyi şekilde faydalanmanızı sağlar ve hem sizin hem de çocuğunuz için güvenli bir sürüşü garanti eder.

バグー フォックス 3の機能に関する記述に特にご注意ください。製品を最大限に活用できると共に、あなたとお子様のためのスムーズな走行が保証されます。

Bugaboo Fox 3의 모든 기능을 안전하게 활용할 수 있도록 제품의 모든 특징을 반드시 확인해 주십시오.

请特别关注 Bugaboo Fox 3的所有特性。这可让您充分使用该产品，并确保您和您的孩子享受平稳的乘用体验。

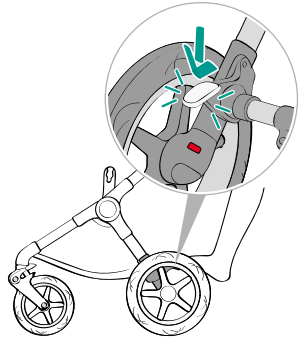

1 .....

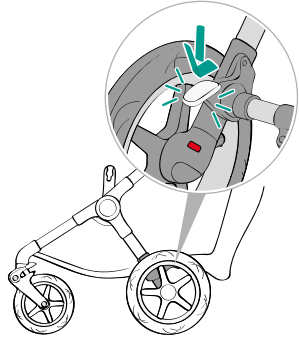
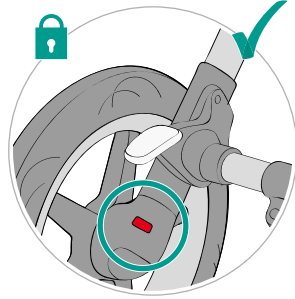

2 .....

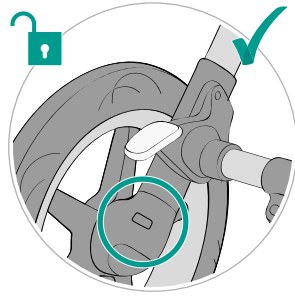

1 .....

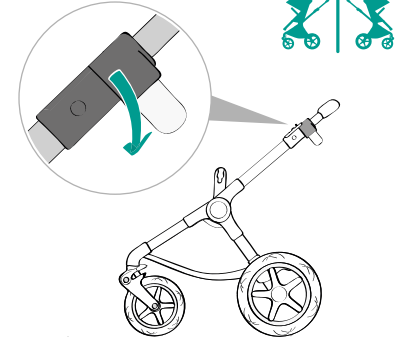
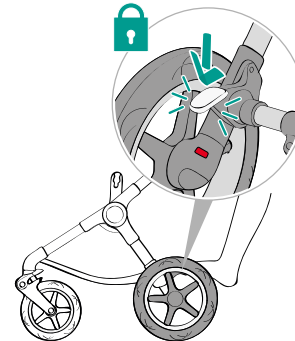

2 .....

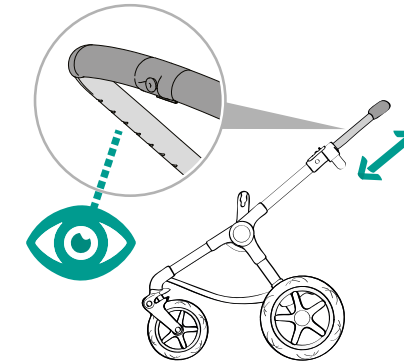

3 .....

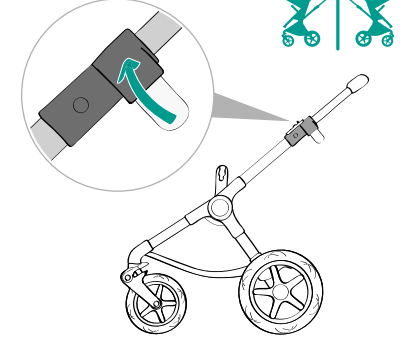

4 .....

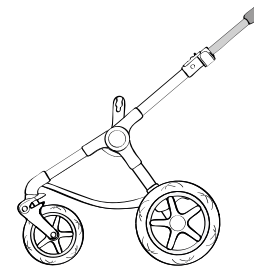

.....

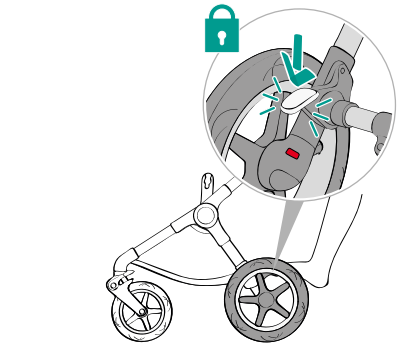

1 .....

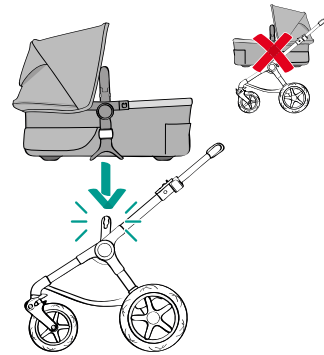

2 .....

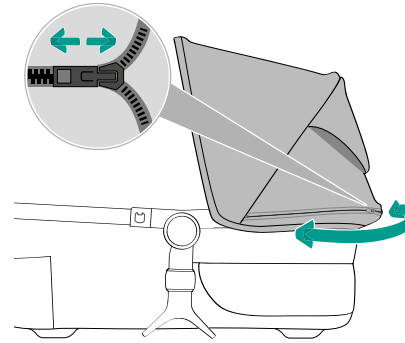

1 .....

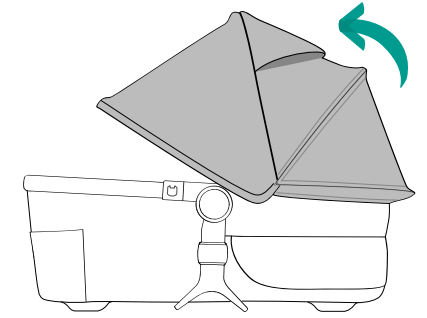

2 .....

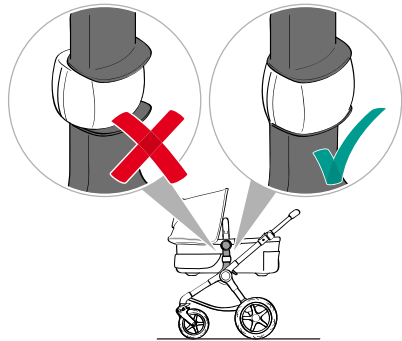

3 .....



4 .....

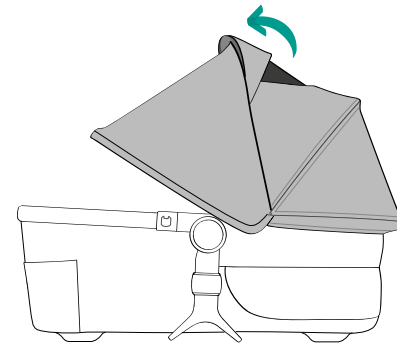

3 .....



.....

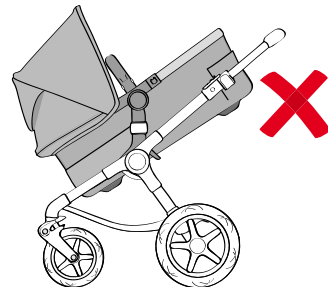

.....

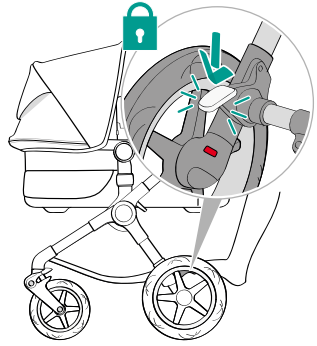

1 .....

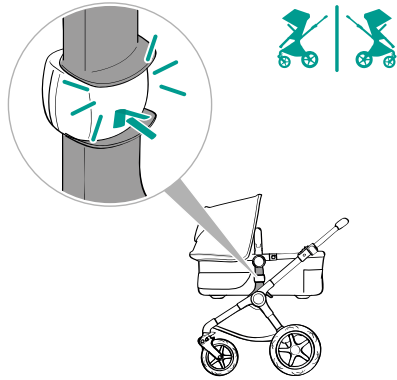

2 .....

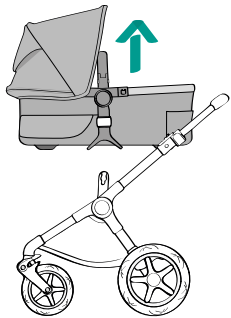

3 .....

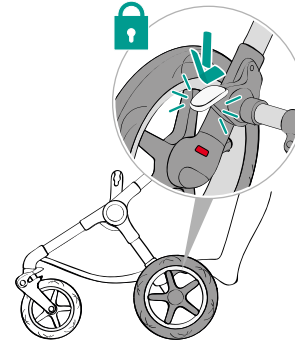

1 .....

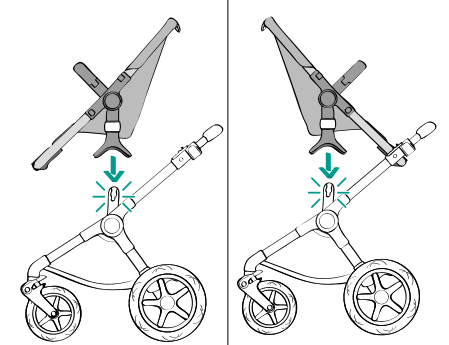

2 .....

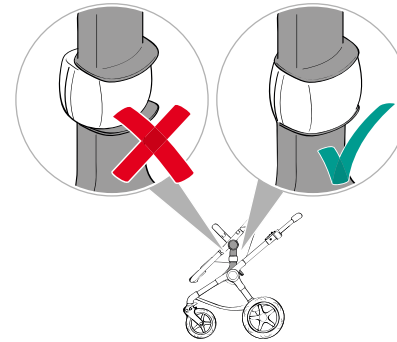

3 .....

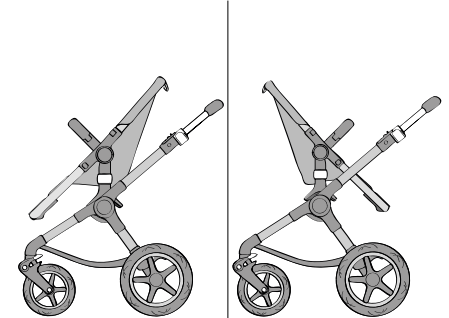

.....

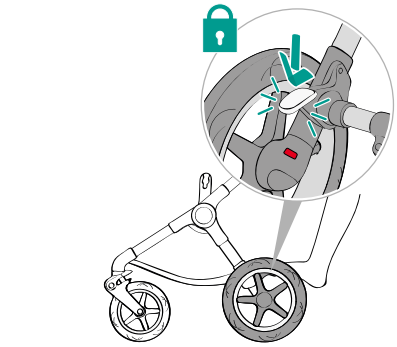

1 .....

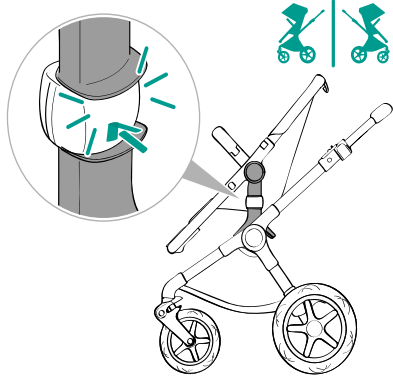

2 .....

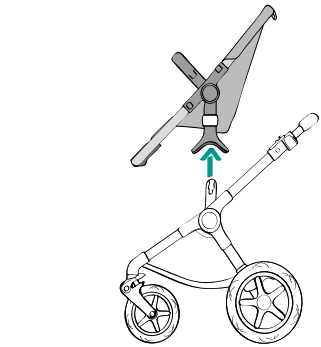

3 .....

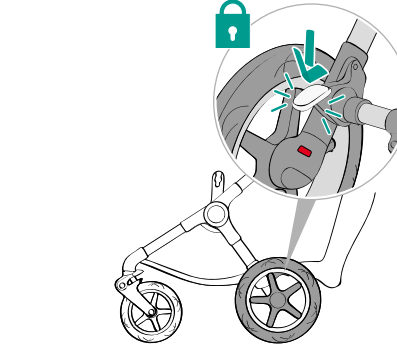

1 .....

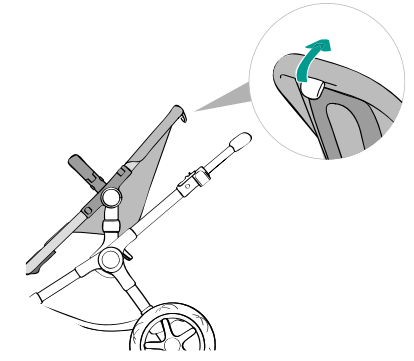

2 .....

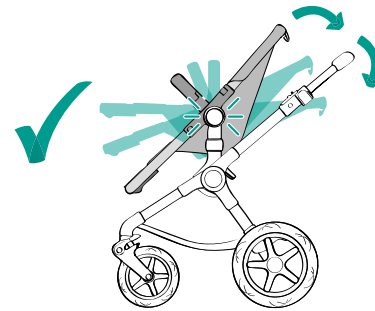

3 .....

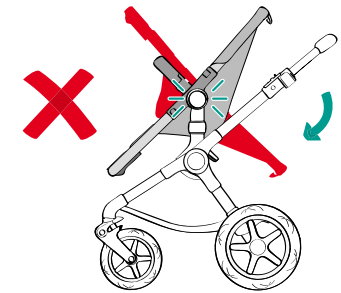

3 .....

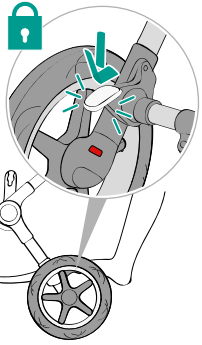

1 .....

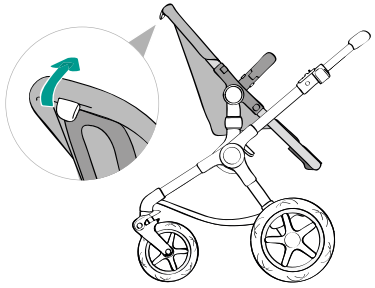

2 .....

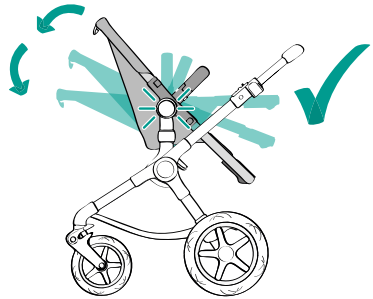

3 .....

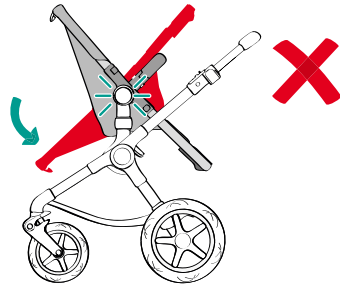

4 .....

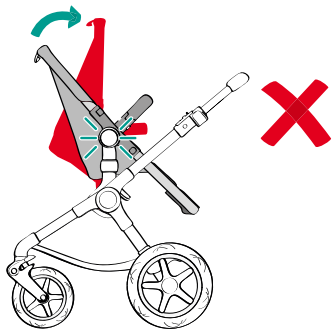

.....

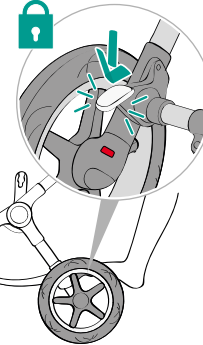

1 .....

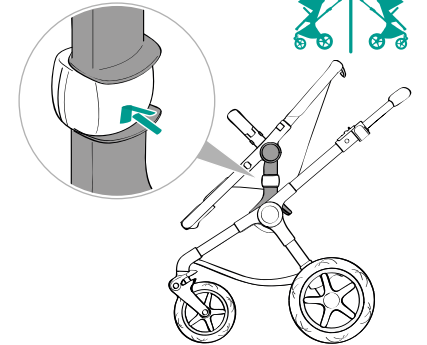

2 .....

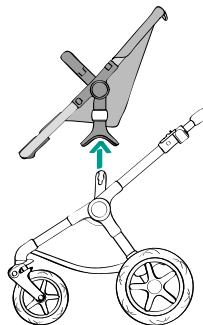

3 .....

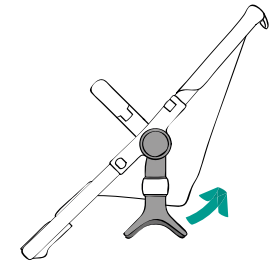

4 .....

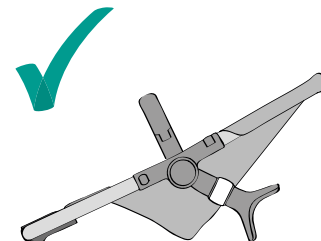

.....



www.bugaboo.com/support/bugaboo-fox

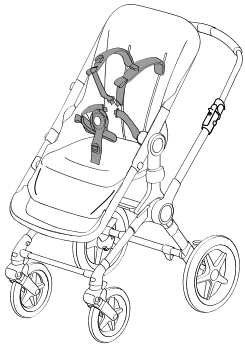

1

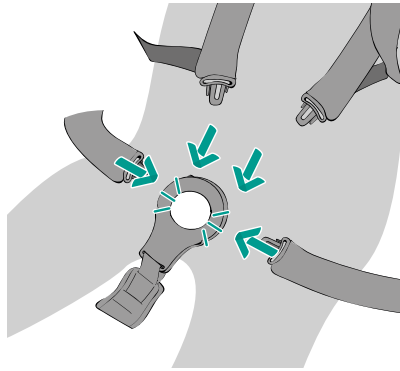

2



www.bugaboo.com/support/bugaboo-fox

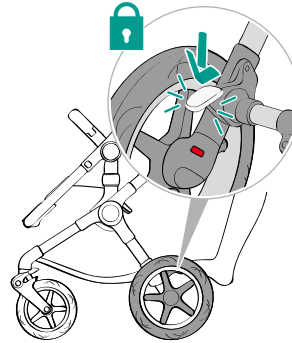

1

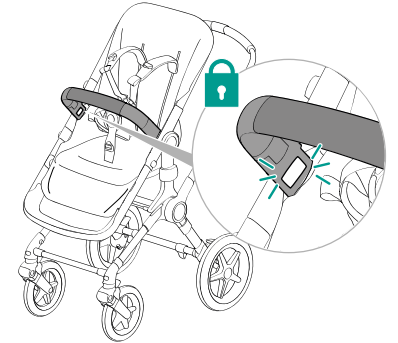

2

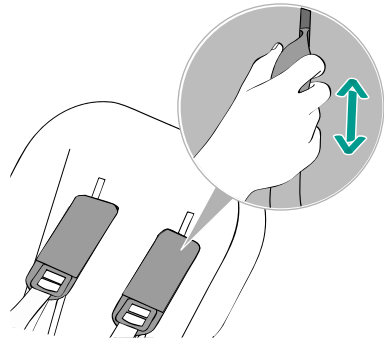

3

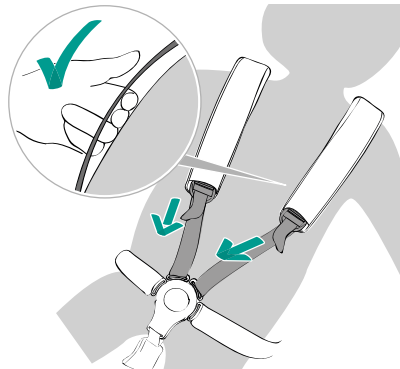

4

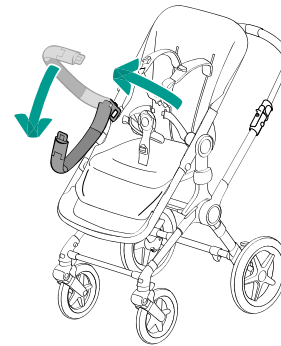

3

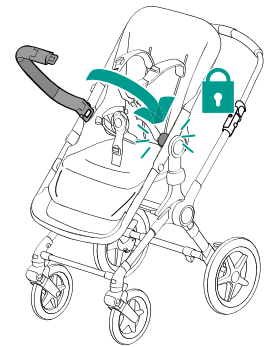

4

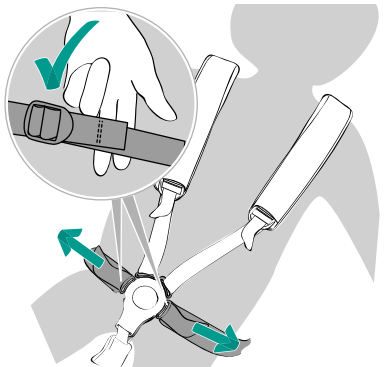

5

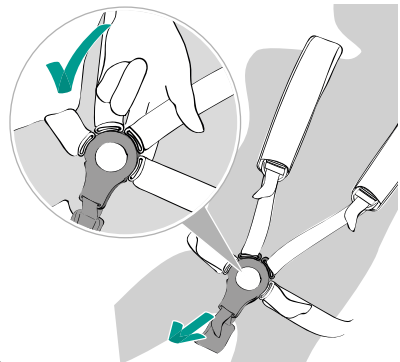

6

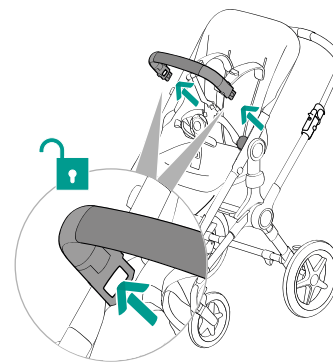

5

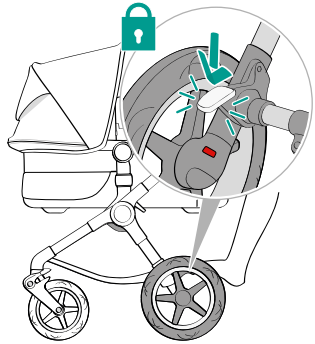

1 .....

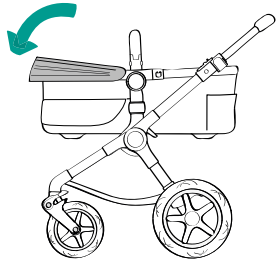

2 .....

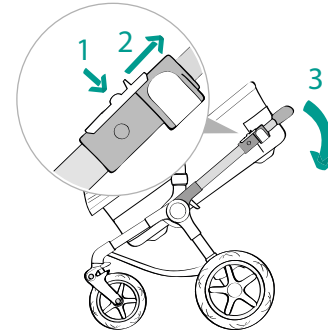

7 .....

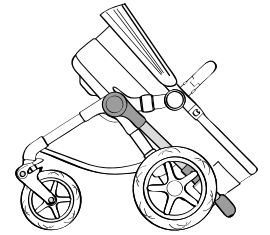

8 .....

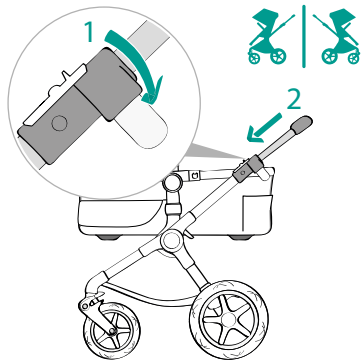

3 .....

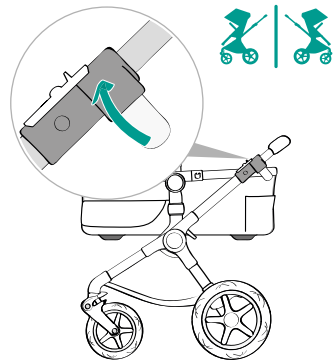

4 .....

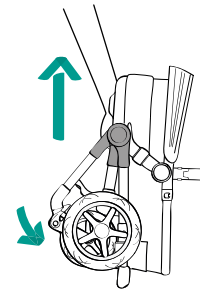

9 .....

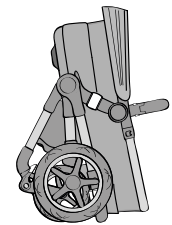

.....

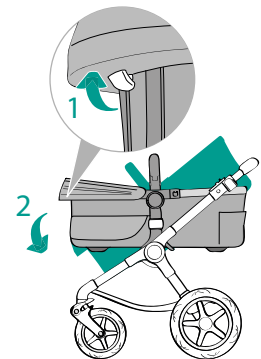

5 .....

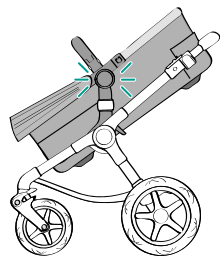

6 .....

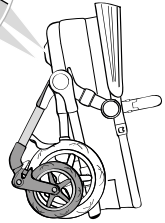
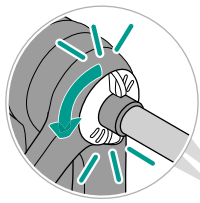
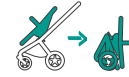
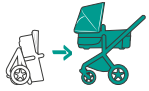

1

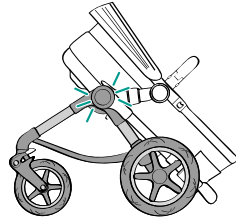

2

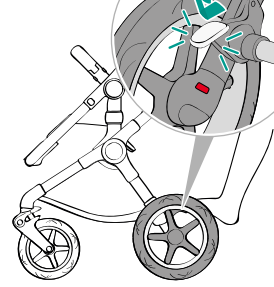
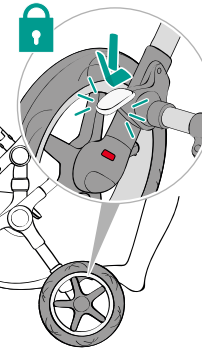

1

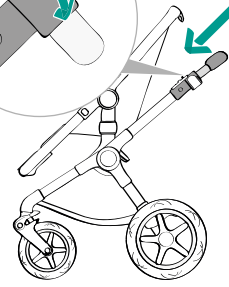
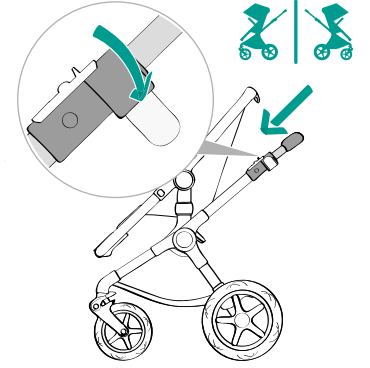

2

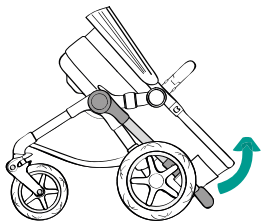

3

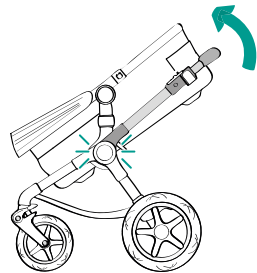

4

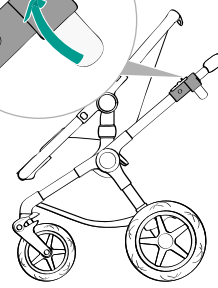
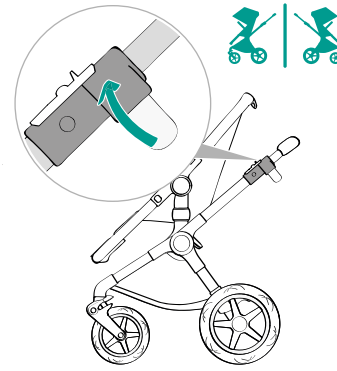

3

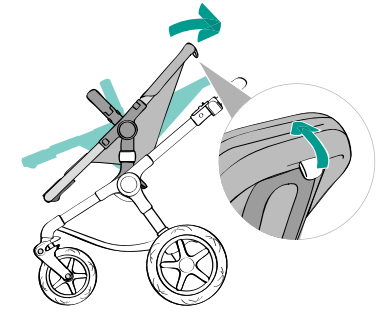

4

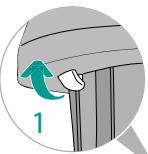

1

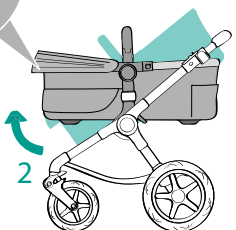

2

5

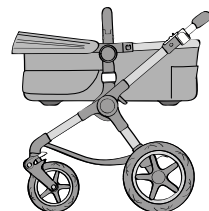

.....

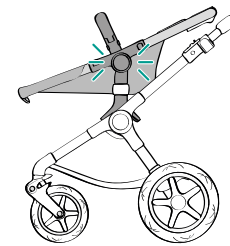

5

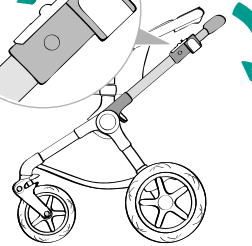
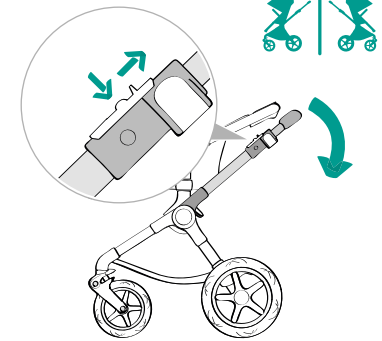

6

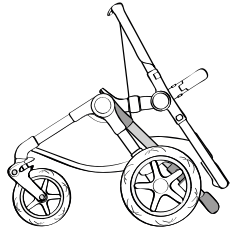
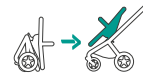

7 .....

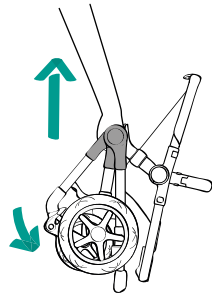

8 .....

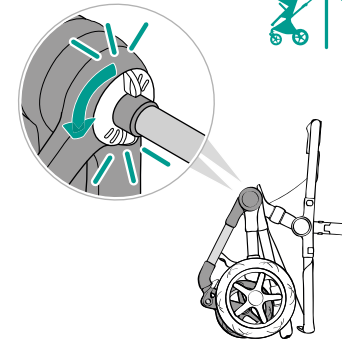

1 .....

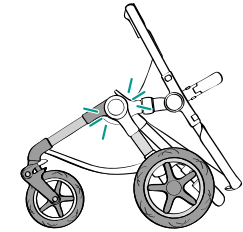

2 .....

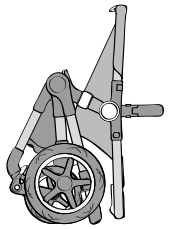

.....

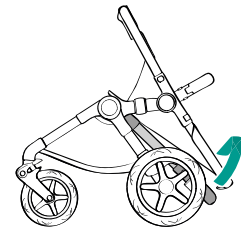

3 .....

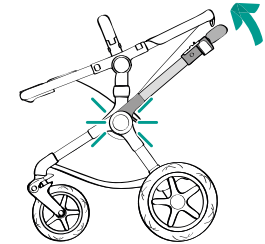

4 .....

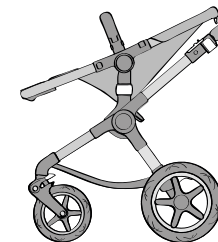

.....

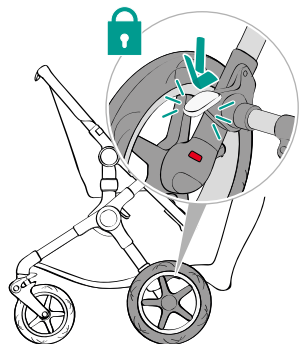
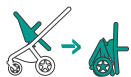

1 .....

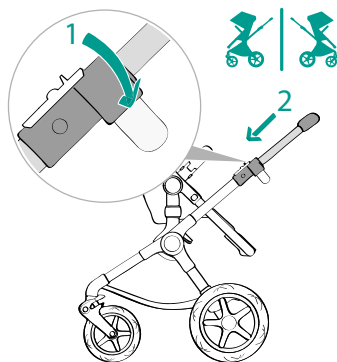

2 .....

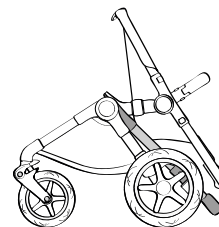

7 .....

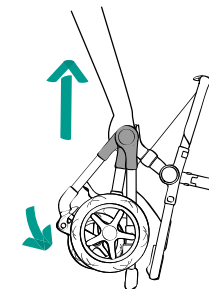

8 .....

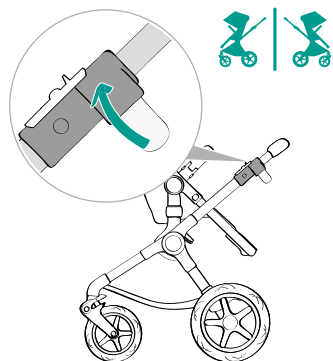

3 .....

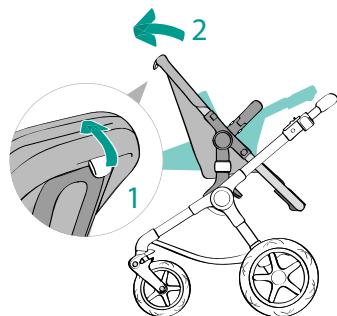

4 .....

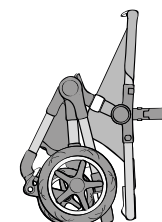

.....

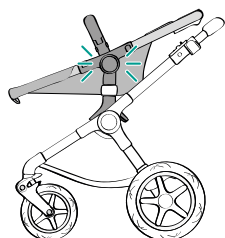

5 .....

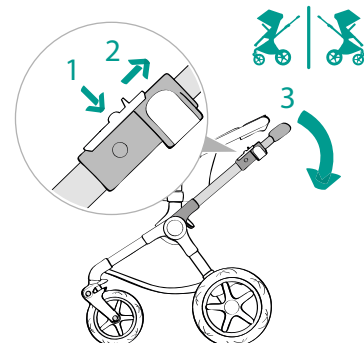

6 .....

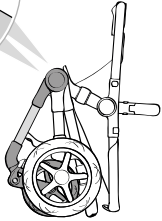
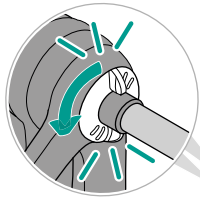
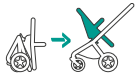

1

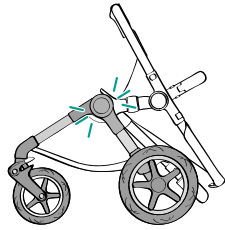

2

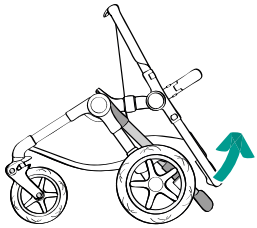

3

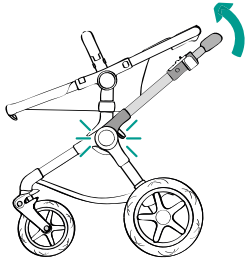

4

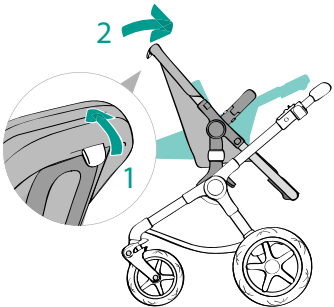

5

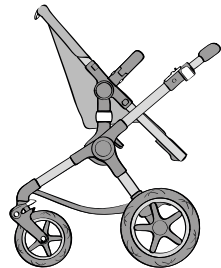

6

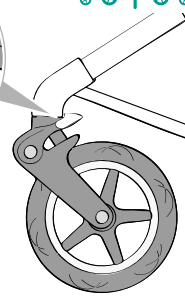

1

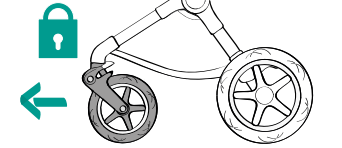

2

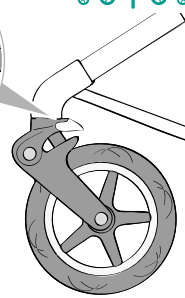
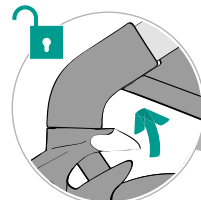

3

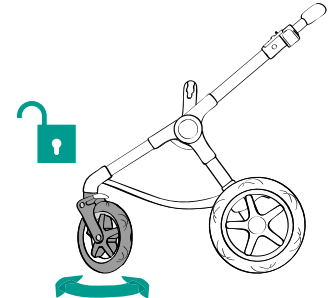

4

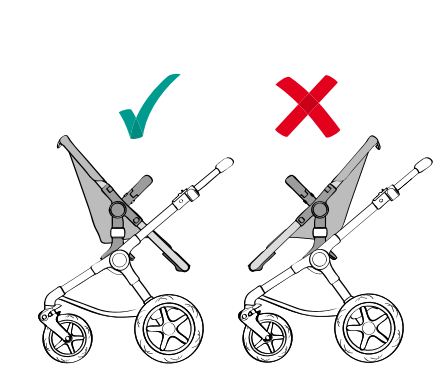

1 .....

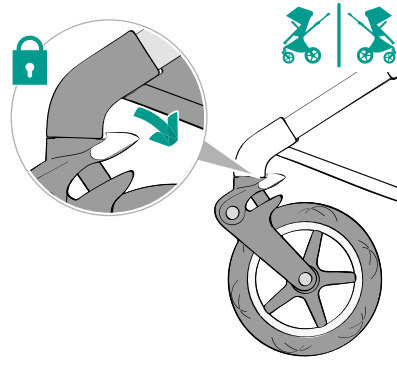

2 .....

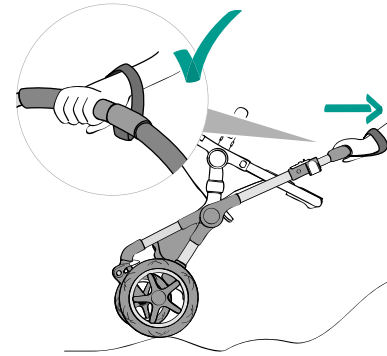

7 .....

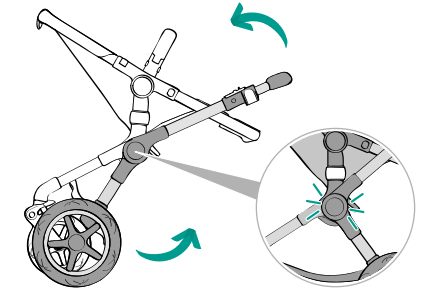

8 .....

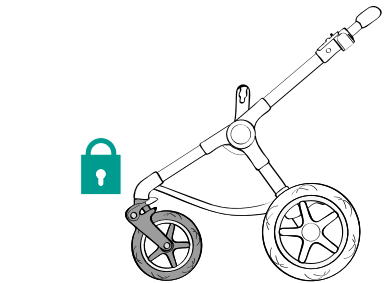

3 .....

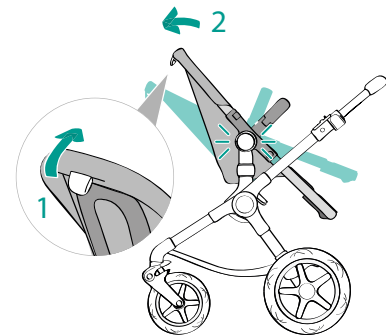

4 .....

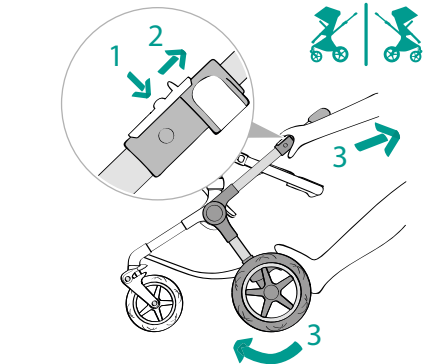

5 .....

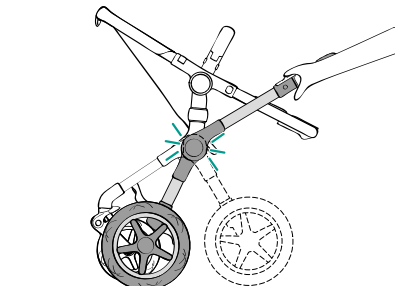

6 .....

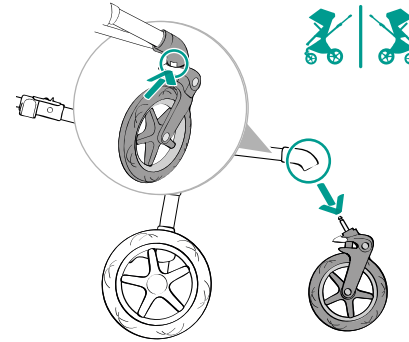

1 .....

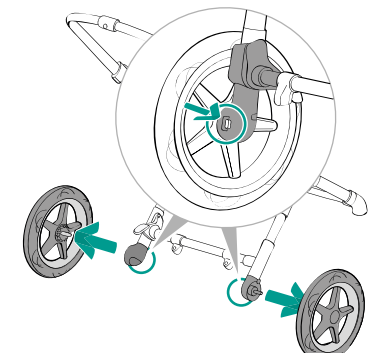

2 .....

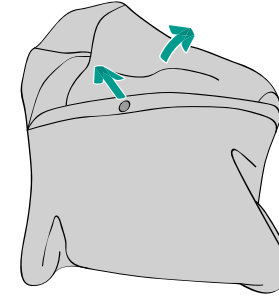
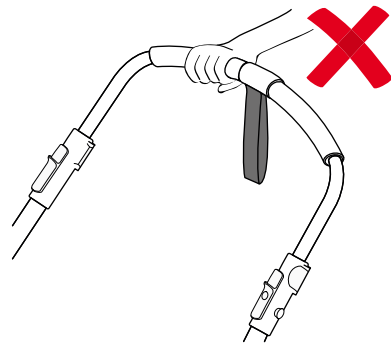
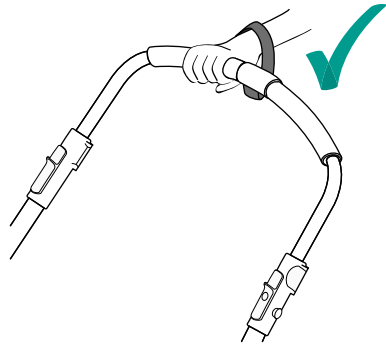

1

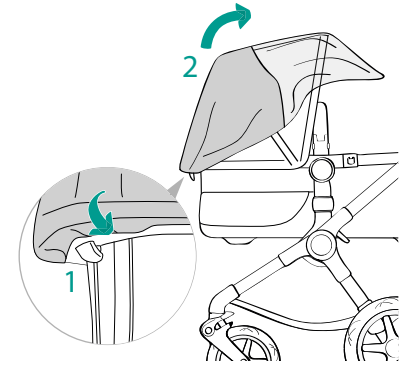

2

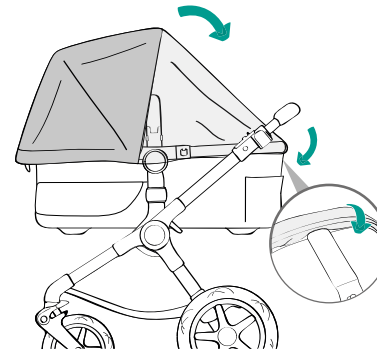

3

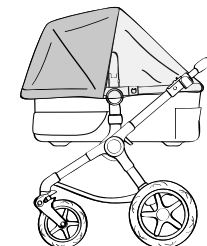
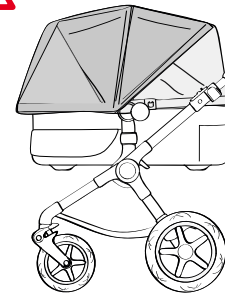
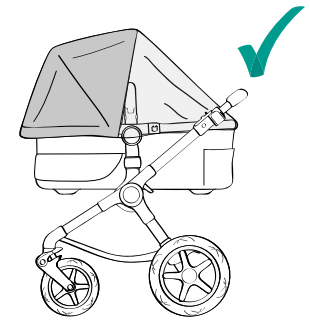

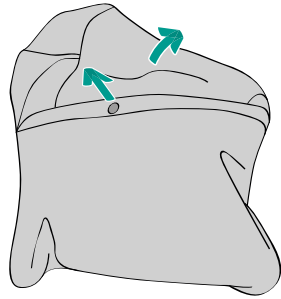

1 .....

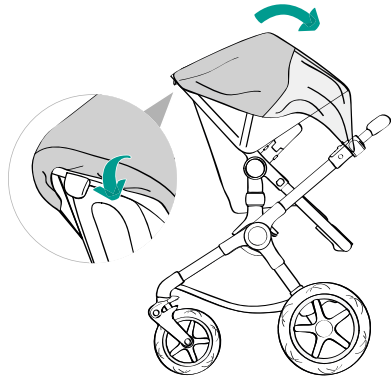

2 .....

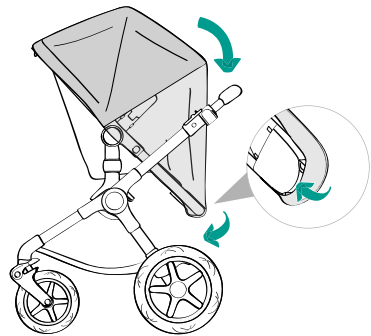

3 .....

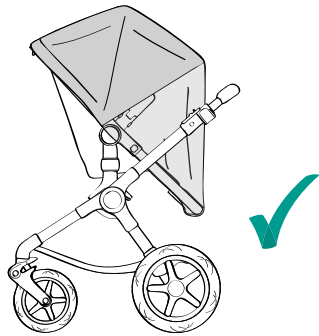

4 .....

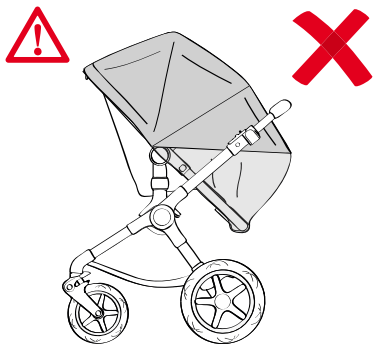

5 .....

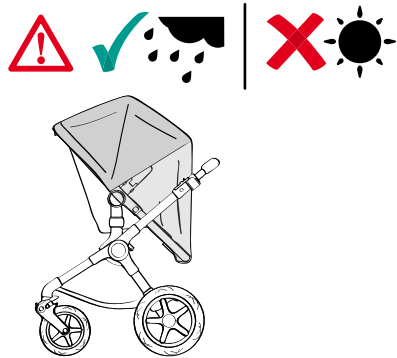

6 .....

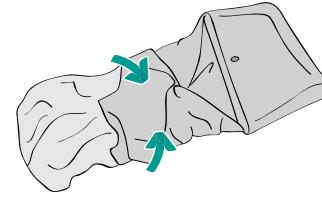

1 .....

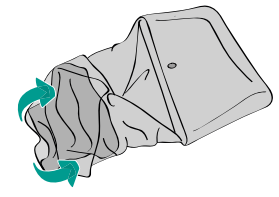

2 .....

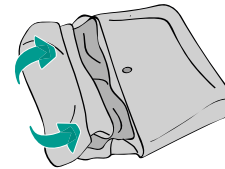

3 .....

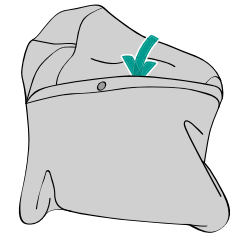

4 .....

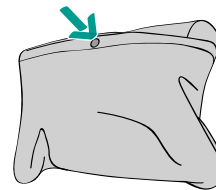

5 .....

The information contained herein is subject to change without notice. Bugaboo International BV shall not be liable for technical errors or omissions contained herein. The purchased product may differ from the product as described in this user guide. Our most recent user guides can be requested at our service departments or at [www.bugaboo.com](http://www.bugaboo.com).

© 2021 Bugaboo International BV. BUGABOO, BUGABOO CAMELEON, BUGABOO BEE, BUGABOO DONKEY, BUGABOO FOX, BUGABOO TURTLE, BUGABOO ANT, BUGABOO LYNX, BUGABOO STARDUST and the Bugaboo logos are registered trademarks. The Bugaboo® strollers are patented and design protected.



**Bugaboo Europe & Asia**

Bugaboo International B.V.  
Paasheuvelweg 9 a-b  
1105 BE Amsterdam Zuidoost  
The Netherlands

**Bugaboo UK Limited (07785001)**

Unit 3 & 4 Riverside Barns  
Remenham Lane  
Remenham, Henley-On-Thames  
RG9 3DB  
England

**Bugaboo Russia**

ООО Бугабу Рус, 121471,  
улица Рябиновая, дом 26, стр.1  
город Москва  
Россия

**Bugaboo North America Inc.**

142 W 57th St New York  
New York 10019  
United States of America

**Bugaboo Australia**

Bugaboo Australia Pty Limited  
Service department Suite 2, Level 2  
156 Edgecliff Road Woollahra, NSW 2025  
Australia

**Bugaboo Japan K.K.**

100-0004  
SPACES大手町  
大手町1-6-1 大手町ビル1階  
東京都千代田区  
Japan

**Bugaboo Korea Co., Ltd.**

부가부코리아(유)  
서울특별시  
송파구 오금로 97  
방이동, 진넥스빌딩 8층  
1577-0680  
Korea

**Bugaboo Shanghai Co., Ltd.**

博各步贸易（上海）有限公司  
上海市崇明区长兴镇潘园公路1800号3号楼  
62889室  
China