

## Meet the Bugaboo Donkey 5

Ontdek de Bugaboo Donkey 5

Poznejte Bugaboo Donkey 5

Mød Bugaboo Donkey 5

Lernen sie den Bugaboo Donkey 5 kennen

Conoce el Bugaboo Donkey 5

Γνωρίστε το Bugaboo Donkey 5

Tutustu Bugaboo Donkey 5 -lastenvaunuihin

Découvrez la Bugaboo Donkey 5

Ti presentiamo Bugaboo Donkey 5

Møt Bugaboo Donkey 5

Poznaj Bugaboo Donkey 5

Conheça o Bugaboo Donkey 5

Знакомство с Bugaboo Donkey 5

Spoznajte Bugaboo Donkey 5

Får vi presentera Bugaboo Donkey 5

Bugaboo Donkey 5 ile tanışma

Bugaboo Donkey 5 の各部の名称

Bugaboo Donkey 5 사용설명서

认识Bugaboo Donkey 5



# What you need

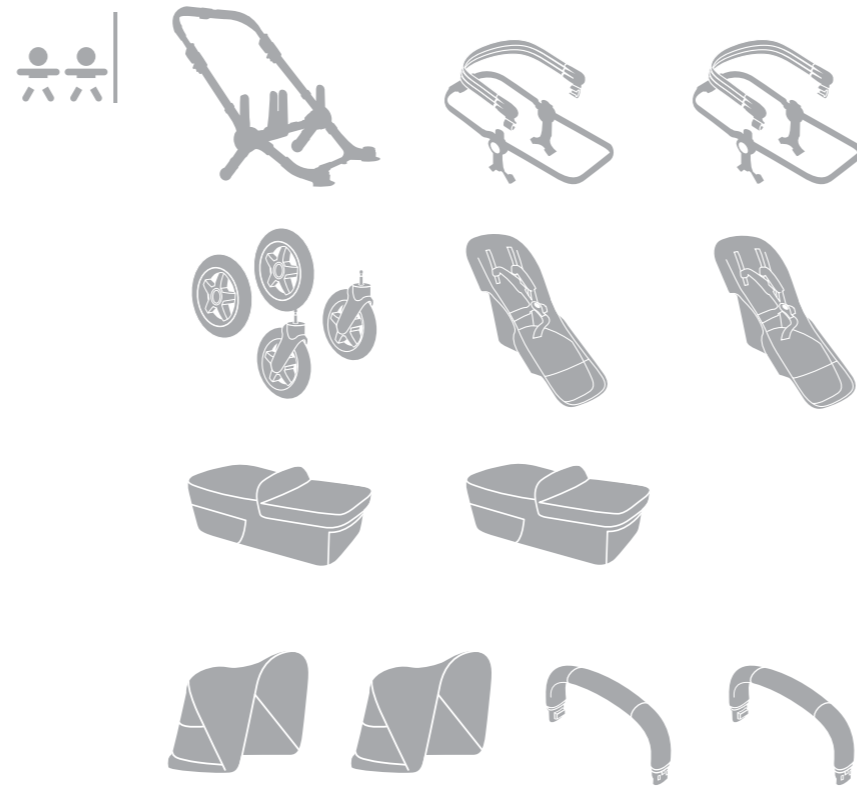

# Parts for set-up

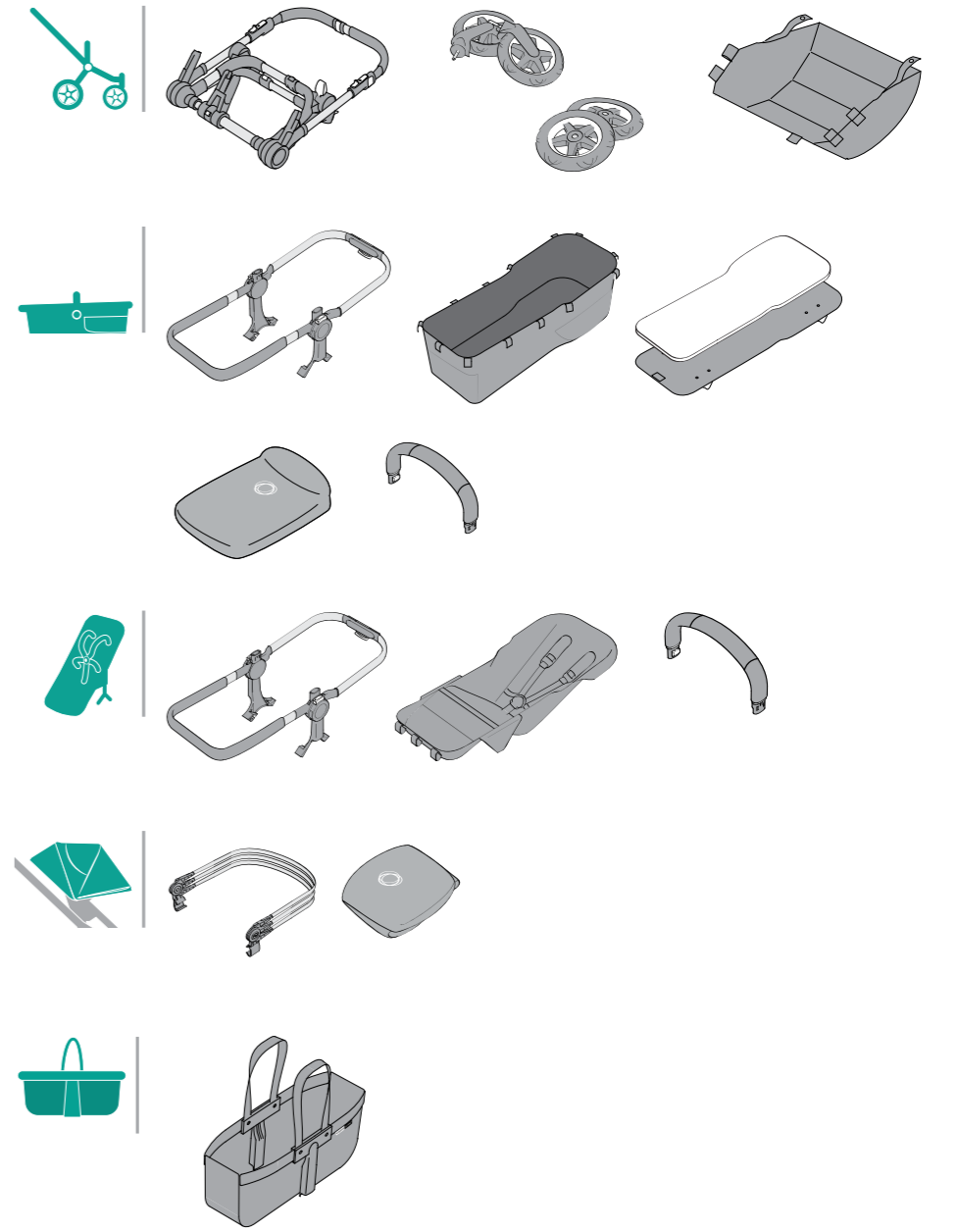

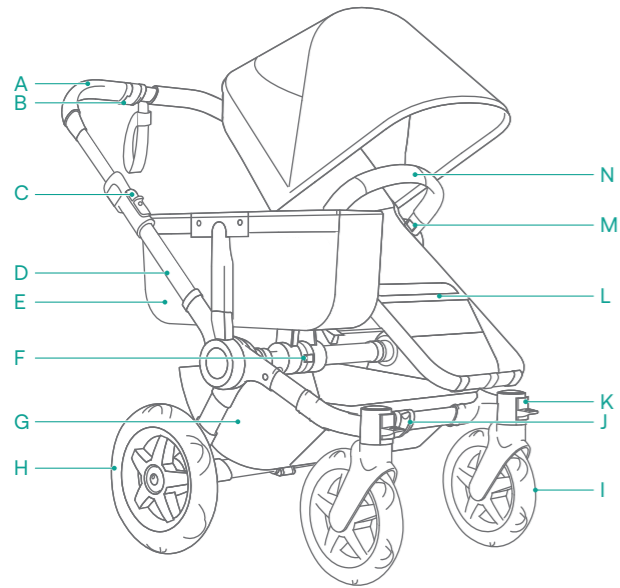

## EN

- A. Handlebar
- B. Handlebar width adjustment clip
- C. Folding lock with secondary lock
- D. Chassis
- E. Side luggage basket
- F. Width adjustment button
- G. Underseat basket
- H. Rear wheel
- I. Swivel wheel
- J. Front width adjustment clip
- K. Swivel lock
- L. Seat
- M. Carry handle release button

- N. Carry handle
- O. Integrated attachment point
- P. Backrest adjustment handle
- Q. Wrist strap
- R. Apron
- S. Bassinet/carrycot
- T. Bassinet/carrycot wire
- U. Brake
- V. Rear width adjustment clip
- W. Sun canopy
- X. Handlebar adjustment clip
- Y. Frame release button
- Z. Wheeled board integrated attachment points

## NL

- A. Duwbeugel
- B. Breedte verstelkleem duwbeugel
- C. Ontgrendelknop (vouwmechanisme) met ontgrendelbeveiliging
- D. Onderstel
- E. Zij-bagagemand
- F. Breedte verstelknop
- G. Bagagemand
- H. Achterwiel
- I. Zwenkwiel
- J. Breedte verstelkleem voorkant
- K. Zwenkwielblokkeerder
- L. Stoel
- M. Draagbeugel-ontgrendelingsknop

- N. Draagbeugel
- O. Bevestigingspunt
- P. Verstelknop rugleuning
- Q. Polsband
- R. Wiegdekje
- S. Wieg
- T. wiegbalein
- U. Rem
- V. Breedte verstelkleem achterkant
- W. Zonnekap
- X. Duwbeugel verstelkleem
- Y. Ontgrendelingsknop onderstel
- Z. Bevestigingspunten geïntegreerd meerrijdplankje

## CS

- A. Rukojeť
- B. Svorka k nastavení šířky rukojeti
- C. Zámek pro složení se sekundárním zámekem
- D. Podvozek
- E. Postranní odkládací koš
- F. Tlačítko pro nastavení šířky
- G. Košík pod sedačku
- H. Zadní kolo
- I. Otočné kolo
- J. Svorka k nastavení přední šířky
- K. Otočný zámek
- L. Sedačka
- M. Tlačítko k uvolnění držadla

- N. Držadlo
- O. Integrovaný úchytný bod
- P. Páčka pro nastavení zadní opěrky
- Q. Popruh na zápěstí
- R. Přikrývka přenosné tašky
- S. Přenosná taška
- T. Výztuha
- U. Brzda
- V. Svorka k nastavení zadní šířky
- W. Stříšky kočárku
- X. Rukojeť svorka pro nastavení tlačítka k uvolnění rámu
- Y. Integrované body pro připevnění pojízdného stupátka

## DA

- A. Styr
- B. Clip til justering af styrbredde
- C. Lås til sammenklapning med sekundær lås
- D. Understel
- E. Sideopbevaringskurv
- F. Breddejusteringsknap
- G. Kurv under sædet
- H. Baghjul
- I. Svinghjul
- J. Clip til justering af forende
- K. Styrehjullås
- L. Sæde
- M. Knap til frigørelse af bærehåndtag

- N. Bærehåndtag
- O. Integreerede påmonteringspunkt
- P. Håndtag til justering af ryglæn
- Q. Håndledsrem
- R. Lift overdække
- S. Lift
- T. Afstiver
- U. Bremse
- V. Clip til justering af bagende
- W. Kaleche
- X. Justeringsclips til styr
- Y. Knap til frigørelse af ramme
- Z. Integreerede samlingspunkter til ståbræt

## DE

- A. Schieberegler
- B. Clip zum einstellen der schiebereglerbreite
- C. Zusammenklapp-sperre mit zusatzverriegelung
- D. Chassis
- E. Seitliche gepäcktasche
- F. Knopf zur einstellung der breite
- G. Untergestellablage
- H. Hinterrad
- I. Schwenkrad
- J. Clip zur einstellung der breite vorn
- K. Schwenkradverriegelung
- L. Sitz
- M. Tragebügel-entriegelungsknopf

- N. Tragebügel
- O. Integrierte Befestigungspunkte
- P. Einstellverriegelung für die rückenlehne
- Q. Sicherheitsriemen für das handgelenk
- R. Winddecke
- S. Liegeaufsatz
- T. Liegeaufsatzstreben
- U. Bremse
- V. Clip zur einstellung der breite hinten
- W. Sonnendach
- X. Schieberegler einstellclip
- Y. Rahmen-entriegelungsknopf
- Z. Integrierte Befestigungspunkte für das Mitfahrbrett

## EL

- A. Χειρολαβή
- B. Κλιπ ρύθμισης πλάτους χειρολαβής
- C. Αναδιπλούμενη ασφάλεια με δευτερεύουσα ασφάλεια
- D. Βάση
- E. Πλαϊνό καλάθι αποσκευών
- F. Κουμπί ρύθμισης πλάτους
- G. Καλάθι κάτω από το κάθισμα
- H. Πίσω τροχός
- I. Περιστρεφόμενος τροχός
- J. Κλιπ ρύθμισης μπροστινού πλάτους
- K. Ασφάλεια περιστρεφόμενου τροχού
- L. Κάθισμα
- M. Κουμπί απελευθέρωσης χειρολαβής

- N. Χερουίλι μεταφοράς
- O. Ενσωματωμένο σημείο σύνδεσης
- P. Λαβή ρύθμισης πλάτης
- Q. Περικάρπιο
- R. Ποδιά πορτ-μπεμπέ
- S. Πορτ-μπεμπέ
- T. Ενισχυτικό πορτ-μπεμπέ
- U. Φρένο
- V. Κλιπ ρύθμισης πίσω πλάτους
- W. Τέντα ηλίου
- X. Κλιπ ρύθμισης χειρολαβής
- Y. Κουμπί απελευθέρωσης πλαϊσίου
- Z. Ενσωματωμένα σημεία σύνδεσης τροχοσανίδας

## ES

- A. Manillar
- B. Pinza de ajuste del ancho del manillar
- C. Seguro de plegado con bloqueo secundario
- D. Chasis
- E. Bolso de equipaje lateral
- F. Botón de ajuste de ancho
- G. Cestilla de compras
- H. Rueda trasera
- I. Rueda giratoria
- J. Pinza de ajuste del ancho delantero
- K. Bloqueo de ruedas giratorias
- L. Silla
- M. Botón de apertura del asa de transporte
- N. Asa de transporte

- O. Puntos de sujeción integrados
- P. Asa de ajuste del respaldo
- Q. Muñequera de seguridad
- R. Cubrepies
- S. Capazo
- T. Varillas de sostén de capazo
- U. Freno
- V. Pinza de ajuste del ancho trasero
- W. Capota
- X. Abrazadera de ajuste del manillar extensible
- Y. Botón de apertura de la estructura
- Z. Puntos de sujeción del patinete acoplado integrados

## FI

- A. Työntöaisa
- B. Työntöaisan säätökiinnike
- C. Taittolukko ja toinen lukko
- D. Runko
- E. Sivukori
- F. Leveyden säätökiinnike
- G. Istuinkori
- H. Takapyörä
- I. Kääntyvä pyörä
- J. Etuleveyden säätökiinnike
- K. Kääntyvien pyörien lukko
- L. Istuin
- M. Kantokahvan vapautusnäppäin

- N. Kantokahva
- O. Integroitu kiinnityspiste
- P. Selkänojan säätökahva
- Q. Käsilenkki
- R. Vaunukopan peite
- S. Vaunukoppa
- T. Vaunukopan tuki
- U. Jarru
- V. Takaleveyden säätökiinnike
- W. Suojakuomu
- X. Työntöaisa säätökiinnitin
- Y. Rungon irrotusnäppäin
- Z. Integroidut seisomatelineen kiinnityspisteet

\* product depicted may not be exactly the same in all regions

<b>FR</b>	A. Guidon	N. Poignée
	B. Clip pour ajuster la largeur du guidon	O. Point d'attache intégré
	C. Mécanisme de verrouillage du repliement avec	P. Poignée d'ajustement du dossier
	D. Châssis	Q. Verrouillage secondaire
	E. Panier latéral	R. Dragonne de poignet
	F. Bouton pour ajuster la largeur du châssis	S. Tablier de nacelle
	G. Panier	T. Nacelle
	H. Roue arrière	U. Baleine de nacelle
	I. Roue pivotante	V. Frein
	J. Clip pour ajuster la largeur de la partie avant du cadre	W. Clip d'ajustement de la largeur de la partie arrière du châssis
	K. Bouton de verrouillage de la roue pivotante	X. Capote
	L. Siège	Y. Clip d'ajustement du guidon bouton de déverrouillage du cadre
	M. Bouton de déverrouillage de la poignée	Z. Points d'attache intégrés de la planche à roulettes

<b>IT</b>	A. Manubrio	N. Maniglione
	B. Clip di regolazione della larghezza del manubrio	O. Punti di aggancio integrati
	C. Secondo pulsante di chiusura	P. Leva di regolazione dello schienale
	D. Telaio	Q. Cinghia da polso
	E. Cesta portaoggetti laterale	R. Coperta navicella
	F. Pulsante di regolazione della larghezza	S. Navicella
	G. Cesta portaoggetti	T. Elemento di rinforzo della navicella
	H. Ruota posteriore	U. Freno
	I. Ruota piroettante	V. Clip di regolazione della larghezza posteriore
	J. Clip di regolazione della larghezza anteriore	W. Cappottina
	K. Blocco ruote piroettanti	X. Clip di regolazione del manubrio
	L. Seggiolino	Y. Pulsante di rilascio telaio
	M. Pulsante di apertura del maniglione	Z. Punti di aggancio integrati per la pedana per il secondo bambino

<b>NO</b>	A. Styre	N. Bærehåndtak
	B. Justeringsklips for styrebredde	O. Justeringshåndtak for ryggstøtte
	C. Håndledd-bånd	P. Klapplås med sekundærlås
	D. Understell	Q. Integrert festepunkt
	E. Sideoppbevaringskurv	R. Overtrekk
	F. Breddjusteringsknapp	S. Bag
	G. Handlenett	T. Bagspile
	H. Bakhjul	U. Bremse
	I. Svinghjul	V. Breddjusteringsklemme for baksida
	J. Justeringsklips for frontbredde	W. Solskjerm
	K. Retningslås for svinghjul	X. Styre justeringsklemme
	L. Sete	Y. Utløsningsknapp for ramme
	M. Utløsningsknapp for bærehåndtak	Z. Integrerte festepunkter for ståbrett

<b>PL</b>	A. Rękojeść	O. Zintegrowany punkt zaczepowy
	B. Zacisk do regulacji szerokości rękojeści	P. Uchwyt do regulacji oparcia
	C. Zamek do składania z dodatkowym zamkiem	Q. Pasek na nadgarstek
	D. Podwozie	R. Przykrycie gondoli
	E. Boczny koszyk bagażowy	S. Gondola
	F. Przycisk regulacji szerokości	T. Usztywnienie
	G. Koszyk pod siedzeniem	U. Hamulec
	H. Koło tylne	V. Zacisk do regulacji szerokości z tyłu
	I. Koło zwrotne	W. Budka przeciwsłoneczna
	J. Zacisk do regulacji szerokości z przodu	X. Zacisk do regulacji rękojeści
	K. Zamek zwrotny	Y. Przycisk do zwalniania ramy
	L. Siedzenie	Z. Zintegrowane punkty zaczepowe dostawki do wózka
	M. Przycisk do zwalniania rączki do przenoszenia	
	N. Rączka do przenoszenia	

<b>PT</b>	A. Manipulo	N. Asa de transporte
	B. Fixador de ajustamento da largura do guidão	O. Ponto de fixação integrado
	C. Botão de fecho com bloqueio secundário	P. Pega de ajustamento do encosto da cadeira
	D. Chassis	Q. Pulseira de segurança
	E. Mala de bagagem lateral	R. Cobre-pés da alcofa
	F. Botão de ajustamento da largura	S. Alcofa
	G. Cesta de bagagem	T. Vareta da alcofa
	H. Roda traseira	U. Travão
	I. Roda giratória	V. Fixador de ajustamento da largura traseira
	J. Fixador de ajustamento da largura dianteira	W. Capota
	K. Bloqueador das rodas giratórias	X. Peças de fixação de regulação do manipulo
	L. Cadeira	Y. Botão de desencaixe da estrutura
	M. Botão de desencaixe da asa de transporte	Z. Pontos de fixação do patim integrados

<b>RU</b>	A. Ручка коляски	N. Ручка для переноски
	B. Верхний зажим для регулировки ширины	O. Интегрированные крепления для аксессуаров
	C. Замок для складывания с вторичным замком	P. Ручка регулировки наклона спинки
	D. Шасси	Q. Ремешок на запястье
	E. Боковая корзина	R. Фартук
	F. Центральная кнопка регулировки ширины	S. Люлька
	G. Корзина под сиденьем	T. Ребро жесткости люльки
	H. Заднее колесо	U. Тормоз
	I. Переднее поворотное колесо	V. Задний зажим регулировки ширины
	J. Нижний зажим регулировки ширины	W. Капюшон
	K. Фиксатор переднего поворотного колеса	X. Зажим, регулирующий высоту ручки коляски
	L. Сиденье	Y. Кнопка для снятия рамы
	M. Кнопка для отсоединения ручки для переноски	Z. Интегрированные крепления для подножки для второго ребенка

<b>SL</b>	A. Ročaj	N. Ročaj
	B. Objemka za prilagoditev širine krmila	O. Vgrajena pritrditvena točka
	C. Zložljiv zaklep z dodatnim zaklepom	P. Ročaj za nastavitev naslonjala
	D. Podvozje	Q. Zapestni trak
	E. Stranska košara	R. Pregrinjalo košare za otroka
	F. Gumb za nastavitev širine	S. Košara za otroka
	G. Košara pod sedežem	T. Ojačevalnik
	H. Zadnje kolo	U. Zavora
	I. Vrtljivo kolo	V. Sponka za nastavitev širine zadnjega dela
	J. Sponka za nastavitev širine sprednjega dela	W. Strešica
	K. Zaklep vrtljivih koles	X. Ročaj zaponka za nastavitev
	L. Sedež	Y. Gumb za sprostitev okvirja
	M. Gumb za sprostitev ročaja	Z. Vgrajene pritrditvene točke za ploščo na kolesih

<b>SV</b>	A. Styre	N. Bärhandtag
	B. Styre med justeringsklämma	O. Inbyggd fästpunkt
	C. Fällningsspärr med sekundärt lås	P. Ryggstödet justeringshandtag
	D. Chassi	Q. Handledsband
	E. Sidobagagekorg	R. Liggdellock
	F. Breddjusteringsknapp	S. Liggdel
	G. Bagagekorg	T. Liftstöd
	H. Bakhjul	U. Broms
	I. Swivelhjul	V. Bakre breddjusteringsklämma
	J. Främre breddjusteringsklämma	W. Sufflett
	K. Swivelås	X. Styre justeringsklämma
	L. Sittedel	Y. Ramens frigöringsknapp
	M. Bärhandtagets frigöringsknapp	Z. Inbyggda fästpunkter för ståbråda

TR

- A. Tutma kolu
- B. Tutma kolu genişlik ayarlama klipsi
- C. İkincil kilitle katlama kilidi
- D. Şasi
- E. Yan bagaj sepeti
- F. Genişlik ayarlama düğmesi
- G. Koltuk altı sepeti
- H. Arka tekerlek
- I. Döner tekerlek
- J. Ön genişlik ayarlama klipsi
- K. Döner kilit
- L. Koltuk
- M. Taşıma kolu serbest bırakma düğmesi
- N. Taşıma kolu

- O. Entegre edilmiş bağlantı noktası
- P. Arkalık ayarlama tutacağı
- Q. Bilek kayışı
- R. Önlük
- S. Beşik
- T. Dilim
- U. Fren
- V. Arka genişlik ayarlama klipsi
- W. Güneş gölgesi
- X. Tutma kolu ayarlama klipsleri
- Y. İskelet serbest bırakma düğmesi
- Z. Entegre edilmiş tekerlekli plaka bağlantı noktası

JA

- A. ハンドルバー
- B. ハンドルバー幅調整クリップ
- C. リストストラップ
- D. シャーシ
- E. サイドの荷物バスケット
- F. 幅調整ボタン
- G. アンダーシートバスケット
- H. 後ろホイール
- I. スイベルホイール
- J. 前幅調整クリップ
- K. スイベルロック
- L. シート
- M. キャリールハンドル解除ボタン
- N. キャリールハンドル

- O. アクセサリー接続点
- P. バックレスト調整ハンドル
- Q. セカンダリロック付き折りたたみロック
- R. エブロン
- S. バシネット/キャリアコット
- T. バシネット/キャリアコットワイヤー
- U. ブレーキ
- V. 後ろ幅調整クリップ
- W. サンキャノピー
- X. ハンドルバー調整クリップ
- Y. フレーム解除ボタン
- Z. 接続点(コンフォートホイールボード)

KO

- A. 핸들바
- B. 핸들바 조절 클립 교체 세트
- C. 보조 잠금장치가 있는 폴딩 락
- D. 새시
- E. 사이드 러기지 바스켓
- F. 폭 조절 버튼
- G. 언더시트 바스켓
- H. 뒷바퀴
- I. 회전 바퀴
- J. 전면 폭 조절 클립
- K. 회전 잠금 장치
- L. 시트
- M. 캐리 핸들 탈착 버튼
- N. 캐리 핸들

- O. 통합 장착 포인트
- P. 등받이 조절 핸들
- Q. 손목 스트랩
- R. 배시넷 커버
- S. 배시넷
- T. 배시넷 와이어
- U. 브레이크
- V. 후면 폭 조절 클립
- W. 씬 캐노피
- X. 핸들바 조절 클립
- Y. 프레임 탈착 버튼
- Z. 바퀴달린 보드 통합 장착 포인트

ZH

- A. 手把管
- B. 手把管宽度调节扣
- C. 手腕织带
- D. 车架
- E. 侧行李篮
- F. 宽度调节按钮
- G. 置物篮
- H. 后轮
- I. 转向轮
- J. 前侧宽度调节扣
- K. 转向锁
- L. 座椅
- M. 前扶手释放按钮
- N. 前扶手

- O. 配件连接点
- P. 椅背调节手把
- Q. 带辅助开关按钮的安全锁
- R. 脚罩
- S. 提篮/婴儿床
- T. 提篮/婴儿床头带
- U. 刹车
- V. 后侧宽度调节扣
- W. 遮阳篷
- X. 手把管调节扣
- Y. 提篮释放按钮
- Z. 集成式儿童踏板配件搭接口

# User guide - visual language



Visual check OK  
 Afbeelding controle OK  
 Vizuální kontrola OK  
 Visuel kontrol OK  
 Optische Kontrolle OK  
 Οπτικός έλεγχος OK  
 Comprobación visual correcta  
 Silmävarainen tarkistus OK  
 contrôle visuel OK  
 Esito positivo del controllo visivo

Visuell kontroll OK  
 Kontrola wzrokowa OK  
 Verificação visual OK  
 Наружный осмотр не выявил неисправностей  
 Znak 'pravilno'  
 Visuell kontroll OK  
 Görsel kontrol tamam  
 目視点検 OK  
 육안 확인 정상  
 正确的效果



Visual check wrong  
 Afbeelding controle niet goed  
 Vizuální kontrola - špatně  
 Visuel kontrol ikke korrekt  
 Optische Kontrolle falsch  
 Οπτικός έλεγχος λάθος  
 Comprobación visual incorrecta  
 Silmävarainen tarkastus ei hyväksyttävä  
 Contrôle visuel erreur  
 Esito negativo del controllo visivo

Visuell kontroll feil  
 Kontrola wzrokowa negatywna  
 Verificação visual errada  
 Наружный осмотр выявил неисправность  
 Znak 'napačno'  
 Visuell kontroll fel  
 Görsel kontrol yanlış  
 目視点検間違い  
 육안 확인이 틀림  
 错误的效果



Audible click  
 Hoorbare klik  
 Slyšitelné cvaknutí  
 Tydelig kliklyd  
 Hörbares Klickgeräusch  
 Ηχητικό κλικ  
 Clic sonoro  
 Kuulet naksahduksen  
 Clic audible  
 Scatto (clic)

Hörbart klick  
 Słyszalny kliknięcie  
 Clique audible  
 Слышимый щелчок  
 Zvočni klik  
 Hörbart klickande ljud  
 Duyulabilir klik sesi  
 聞き取れるクリック音  
 찰칵 소리가 들림  
 “咔嚓” 声



Perform action on both sides of the product.  
 Actie verrichten aan beide zijden van het product.  
 Opatření proved'te na obou stranách výrobku.  
 Gør som anvist på begge sider af produktet.  
 Fassen Sie an beiden Seiten des Produkts an.  
 Εκτελέστε την ενέργεια και στις δύο πλευρές του προϊόντος.  
 Realiza la acción en ambos lados del producto.  
 Tee toimet tuotteen molemmilla puollilla.  
 Répétez l'action des deux côtés du produit.  
 Esegui l'operazione su entrambi i lati del prodotto.

Følg instruksjonene på begge sider av produktet.  
 Powtórz czynność z obu stron wózka.  
 Execute a ação em ambos os lados do produto.  
 Выполните это действие с обеих сторон коляски.  
 Ukrepaite na obeh straneh izdelka.  
 Utför åtgärden på båda sidor om produkten.  
 İşlemi, ürünün iki yanına da uygulayın.  
 ベビーカークの両サイドから操作してください。  
 제품의 양쪽에서 작업을 수행해야 합니다.  
 对产品的两侧均执行操作。



When you see this symbol in the instructional part of the user guide, please refer to the warnings chapter for ensuring the safe use of the Bugaboo Donkey 5.

Wanneer je op de instructiepagina's in de gebruiksaanwijzing dit symbool ziet, raadpleeg dan het hoofdstuk met waarschuwingen om er zeker van te zijn dat je de Bugaboo Donkey 5 veilig gebruikt.

Pokud uvidíte v instruktážní části uživatelské příručky tento symbol, podívejte se do kapitoly varování, abyste si ověřili bezpečné používání kočárku Bugaboo Donkey 5.

Når du ser dette symbol i instruktionsdelen af brugervejledningen, skal du bladere om til afsnittet om advarsler for at sikre, at du anvender Bugaboo Donkey 5 korrekt.

Wenn Sie dieses Symbol in der Bedienungsanleitung sehen, lesen Sie bitte den Abschnitt mit den Warnhinweisen, um die sichere Nutzung des Bugaboo Donkey 5 sicherzustellen.

Όταν βλέπετε αυτό το σύμβολο στο τμήμα οδηγιών των οδηγιών χρήσης, παρακαλούμε ανατρέξτε στο κεφάλαιο προειδοποιήσεων για τη διασφάλιση της ασφαλούς χρήσης του Bugaboo Donkey 5.

Cuando veas este símbolo en las instrucciones de la guía del usuario, consulta el capítulo de advertencias para garantizar un uso seguro del Bugaboo Donkey 5.

Tämä symboli ilmaisee käyttöoppaan ohjeosassa vaaraa. Katso lisätietoja varoituksia sisältävästä luvusta ja varmista, että käytät lastenvaunuja turvallisesti.

Lorsque vous apercevez ce symbole dans les instructions du mode d'emploi, veuillez vous référer au chapitre sur les avertissements pour garantir une utilisation en toute sécurité de la Bugaboo Donkey 5.

Quando vedi questo simbolo nelle istruzioni della guida all'uso, fai riferimento al capitolo relativo alle avvertenze per informazioni su come usare Bugaboo Donkey 5 in modo sicuro.

Når du ser dette symbolet i instruksjonsdelen av bruksanvisningen, kan du se kapittelet om advarsler for å sikre at du bruker Bugaboo Donkey 5 på en trygg måte.

Jeśli widzisz ten symbol w instruktażowej części przewodnika, przejdź do rozdziału z ostrzeżeniami. Dzięki temu zyskasz pewność, że korzystasz z wózka Bugaboo Donkey 5 w bezpieczny sposób.

Quando vir este símbolo nas instruções do guia do utilizador, consulte o capítulo de avisos para garantir que utiliza o Bugaboo Donkey 5 de uma forma segura.

Когда вы увидите этот символ в инструкционной части руководства пользователя, см. главу с предупреждениями, чтобы обеспечить безопасное использование коляски Bugaboo Donkey 5.

Če v navodilih v priročniku za uporabnike vidite ta znak, preberite poglavje z opozorili, kjer so navodila za varno uporabo vozička Bugaboo Donkey 5.

Om du ser den här symbolen i anvisningarna i användarhandboken ska du titta i varningskapitlet så att du använder Bugaboo Donkey 5 säkert.

Kullanıcı kılavuzunun açıklamalar kısmında bu simgeyi gördüğünüzde, Bugaboo Donkey 5'in güvenli kullanımını sağlamak için, lütfen uyarılar bölümüne başvurun.

このシンボルがユーザーガイドの使用手順に表示されている場合は、Bugaboo Donkey 5を安全にご使用いただくための警告ページを参照してください。

사용설명서의 지침 부분에서 이 기호를 만나면, Bugaboo Donkey 5의 안전한 사용 섹션의 경고 사항을 참조하십시오.

当您在本说明书的指导说明部分看到这一符号时，请参阅警告章节，确保您将安全使用 Bugaboo Donkey 5。

## white parts

All the white parts of your Bugaboo Donkey 5 are functional. They're the parts that allow you to adapt and change your Bugaboo Donkey 5.

Alle witte onderdelen van uw Bugaboo Donkey 5 hebben een functie. Dit zijn de onderdelen waarmee u uw Bugaboo Donkey 5 kunt verstellen en veranderen.

Všechny bílé části vašeho Bugaboo Donkey 5 jsou funkční. Jsou to části, které vám umožňují přizpůsobit a změnit váš Bugaboo Donkey 5.

Alle de hvide dele på din Bugaboo Donkey 5 er funktionelle. Det er disse dele, der gør det muligt for dig at tilpasse og ændre din Bugaboo Donkey 5.

Alle weißen Teile Ihres Bugaboo Donkey 5 haben spezielle Funktionen/sind funktionell. Das heißt: Mit diesen Teilen können Sie Ihren Bugaboo Donkey 5 einstellen und verändern.

Όλα τα λευκά μέρη του Bugaboo Donkey 5 είναι λειτουργικά. Είναι τα μέρη που σας επιτρέπουν να προσαρμόσετε και να αλλάξετε το Bugaboo Donkey 5 σας.

Todas las piezas blancas de su Bugaboo Donkey 5 son funcionales. Son las piezas que le permiten adaptar y cambiar su Bugaboo Donkey 5.

Kaikki valkoiset osat ovat toiminnallisia Bugaboo Donkey 5 -vaunuissa. Ne ovat osia, joiden voit sovittaa ja muunnella Bugaboo Donkey 5 -lastenvaunuja.

Toutes les parties blanches de votre Bugaboo Donkey 5 sont fonctionnelles. Ces parties vous permettent d'adapter et de modifier votre Bugaboo Donkey 5 selon vos besoins.

Tutte le parti bianche del Bugaboo Donkey 5 sono funzionali. Questi pezzi consentono di adattare e modificare il Bugaboo Donkey 5.

Alle de hvite delene på din Bugaboo Donkey 5 er funksjonelle. Det er deler som gjør det mulig for deg å tilpasse og endre din Bugaboo Donkey 5.

Wszystkie białe części Bugaboo Donkey 5 są funkcjonalne. Są to części umożliwiające adaptowanie i modyfikowanie Bugaboo Donkey 5.

Todas as partes brancas do seu Bugaboo Donkey 5 são funcionais. São as partes que lhe permitem adaptar e mudar o seu Bugaboo Donkey 5.

Все функциональные детали коляски Bugaboo Donkey 5 выделены белым цветом. Эти детали позволяют трансформировать коляску Bugaboo Donkey 5.

Vsi beli deli vašega vozička Bugaboo Donkey 5 so funkcionalni. To so deli, ki vam omogočajo, da prilagodite in spremenite vaš voziček Bugaboo Donkey 5.

Alla vita delar på din Bugaboo Donkey 5 är funktionsdelar. Dessa delar gör att du kan anpassa och ändra din Bugaboo Donkey 5.

Bugaboo Donkey 5 ürününüzün tüm beyaz parçaları işlevseldir. Bunlar Bugaboo Donkey 5 ürününüzü ayarlamanızı ve değiştirmenizi sağlayan parçalardır.

Bugaboo Donkey 5 の白い部品がすべて機能することを確認してください。白い部品を使用して Bugaboo Donkey 5 を調整および変更します。

Bugaboo Donkey 5의 흰색 부품은 모두 기능성이 있습니다. 이 부분은 Bugaboo Donkey 5를 조정하거나 변경할 때 사용됩니다.

Bugaboo Donkey 5的所有白色部件均为功能部件。这些部件能够让你调整和变化您的 Bugaboo Donkey 5。

# Set- up



.....18



.....19



.....21



.....24



.....26



.....29



.....30

# Features

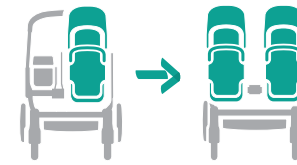

.....34



.....35



.....36



.....37

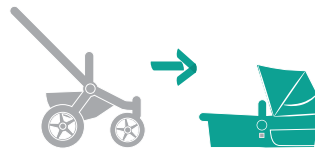

.....38



.....39



.....40



.41



.42

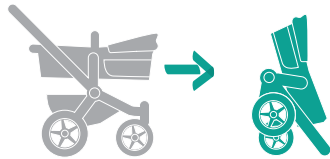

.43



.45

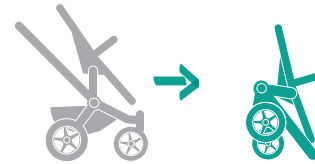

.47



.48



.49



.50

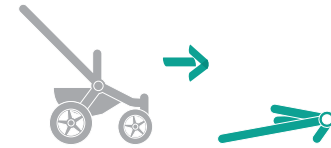

.52



.53



.54



.55



.56

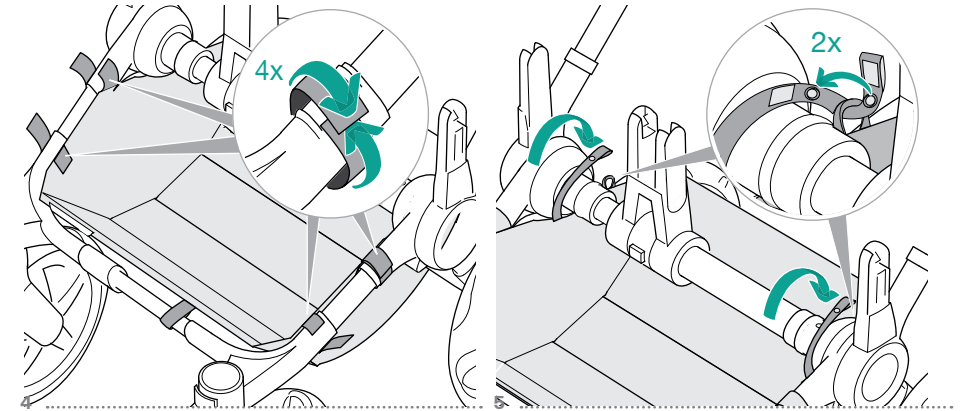
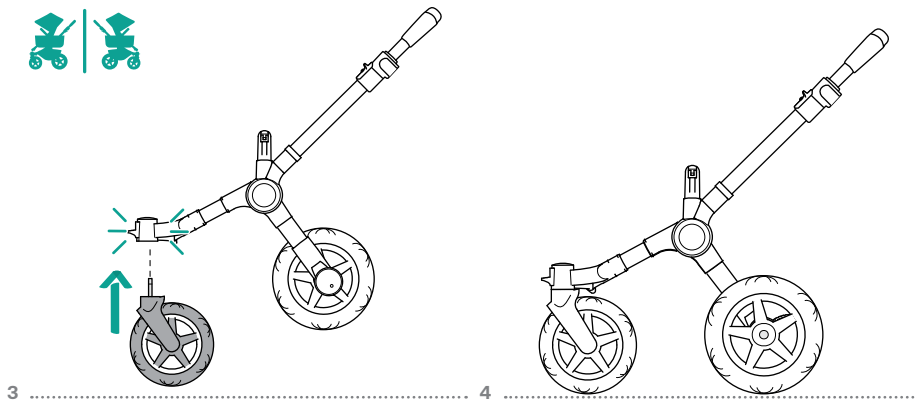
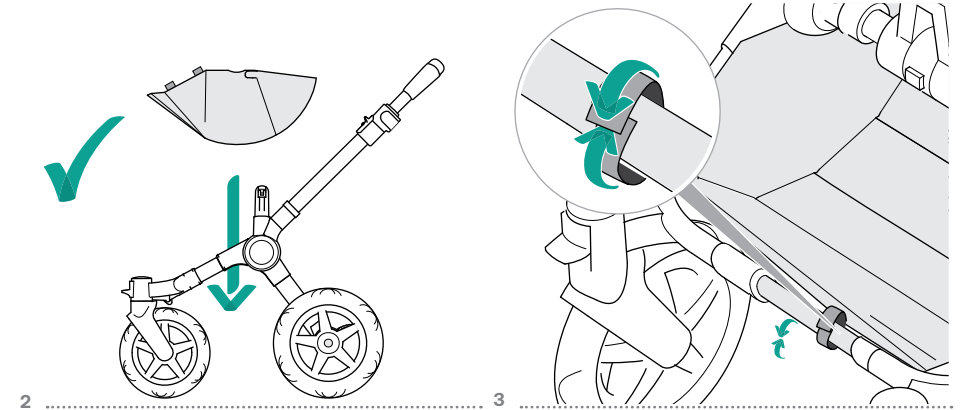
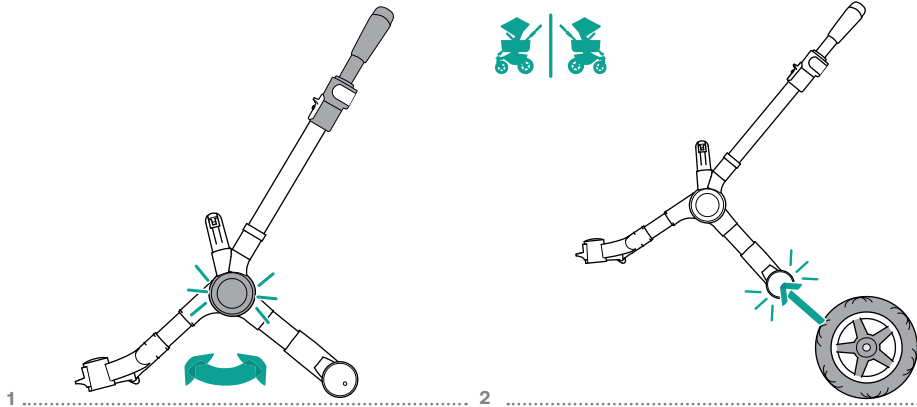
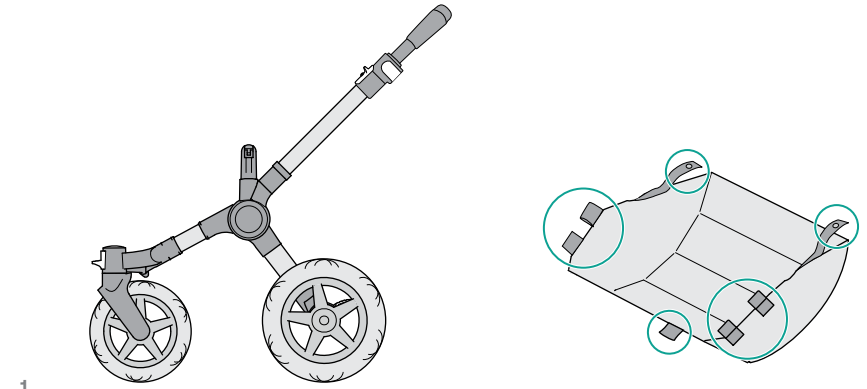
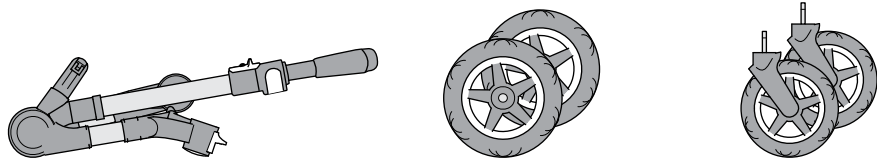

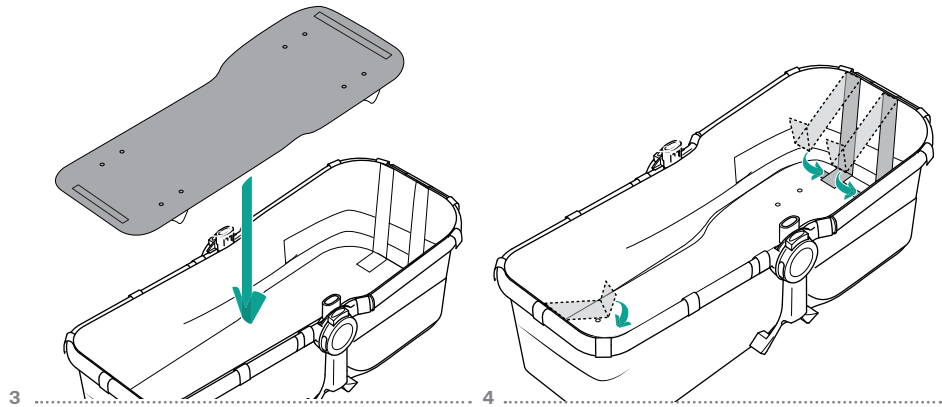
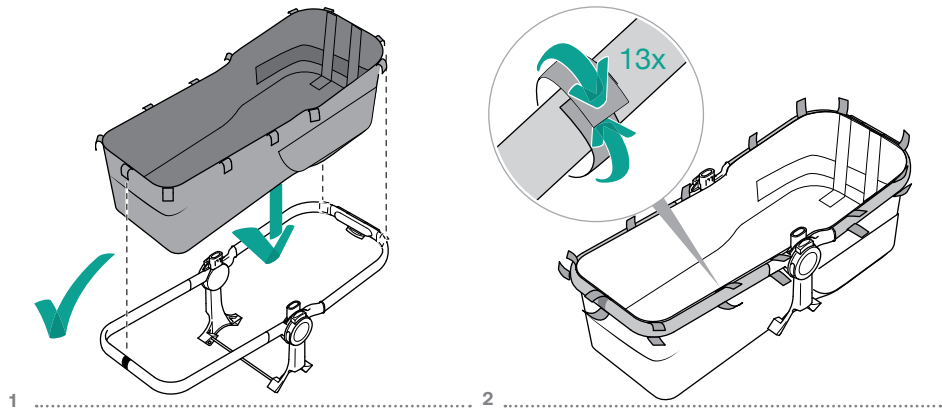
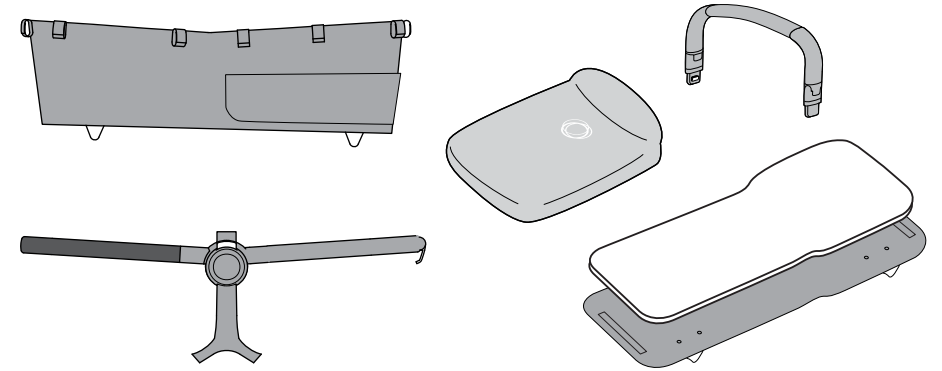
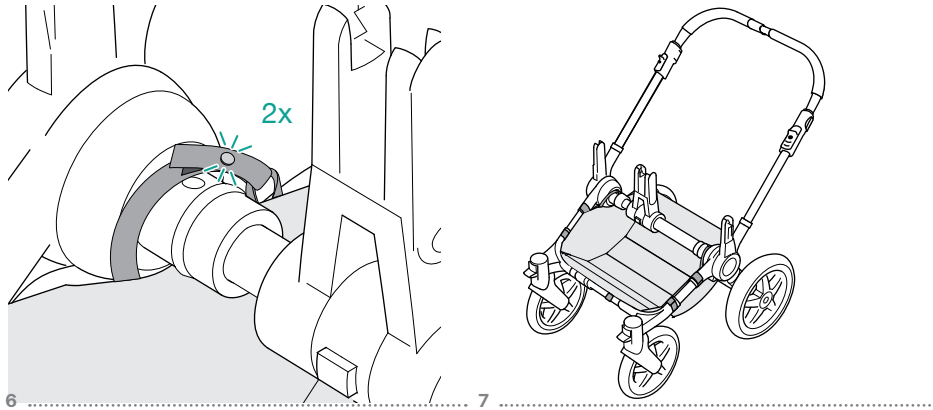

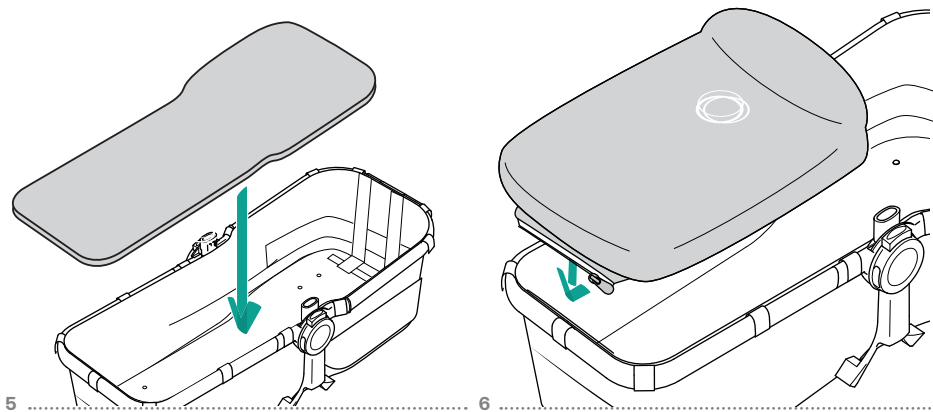

5

6

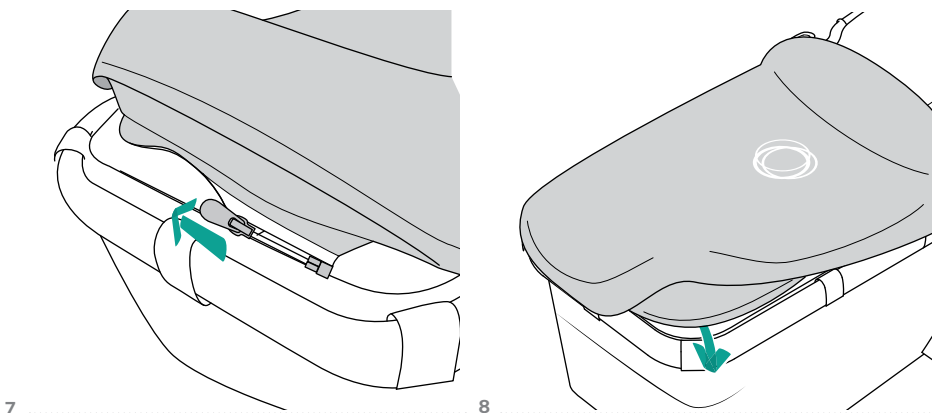

7

8

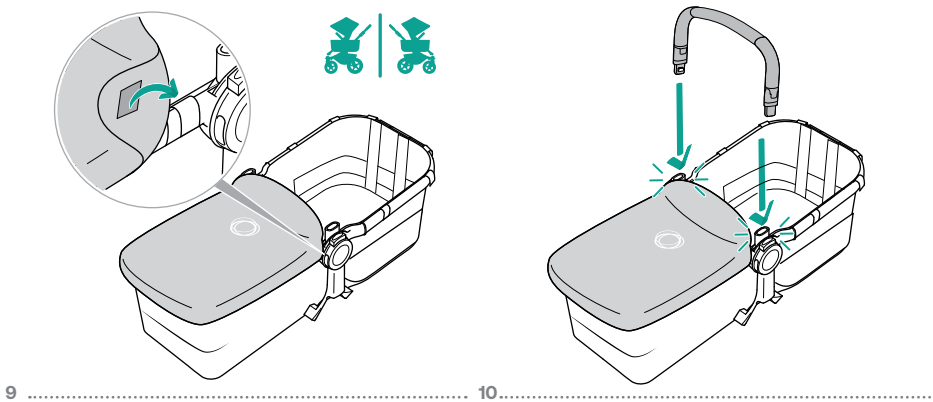

9

10

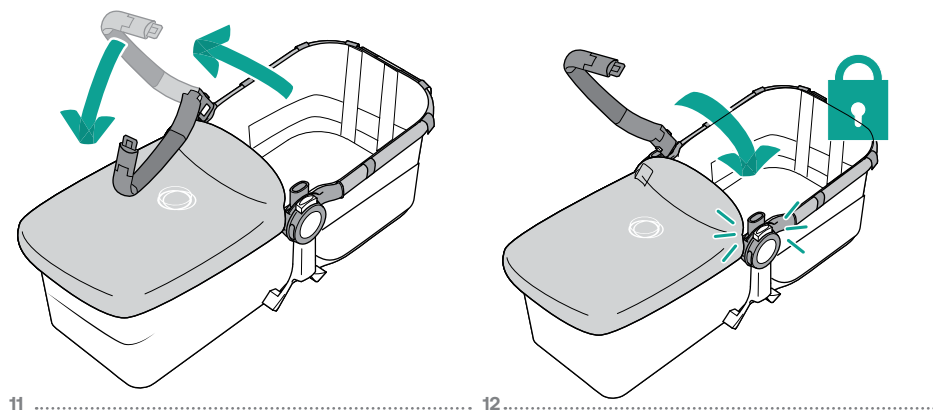

11

12

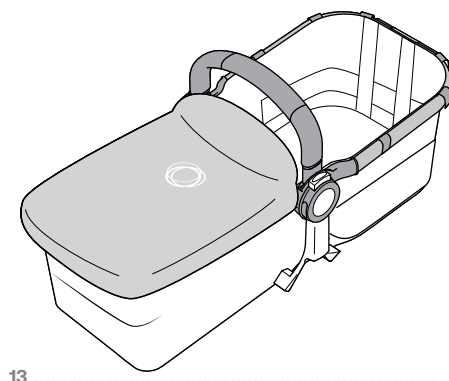

13

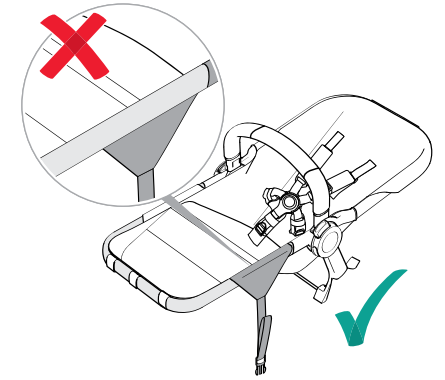
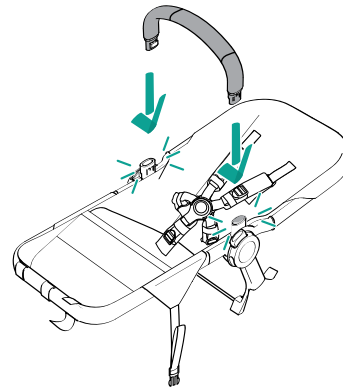
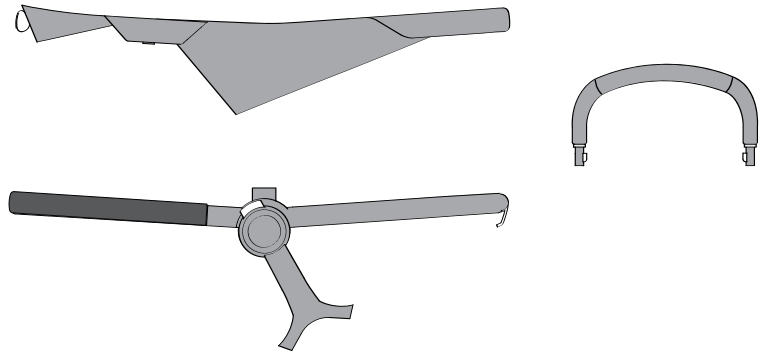

5

6

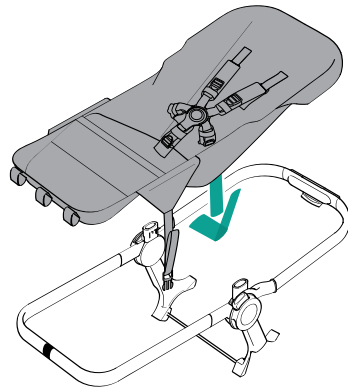
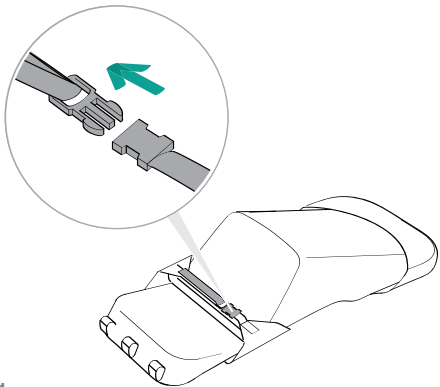

1

2

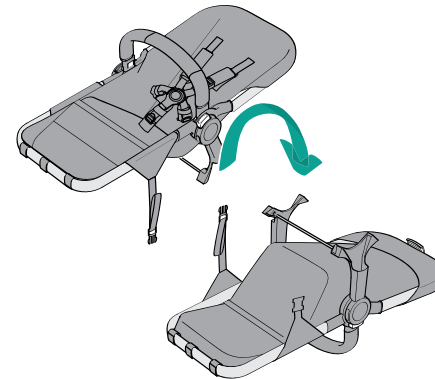

7

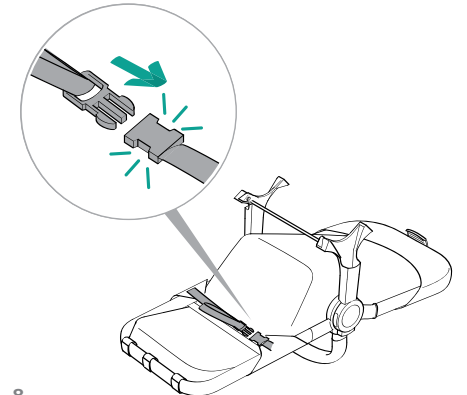

8

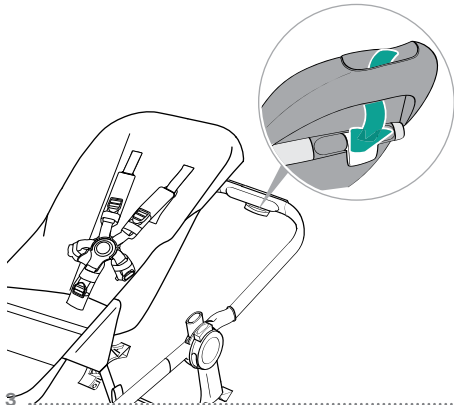

3

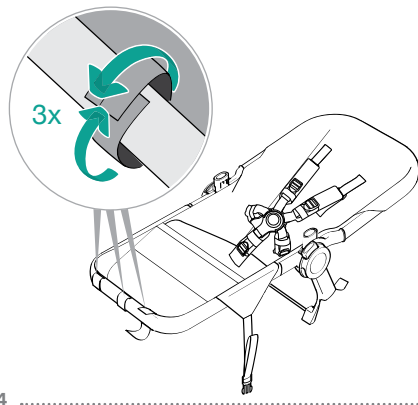

4

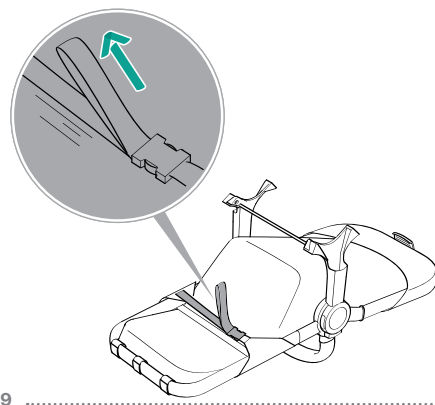

9

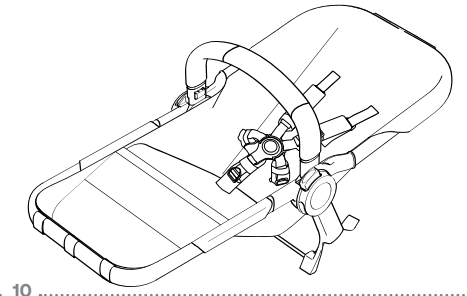

10

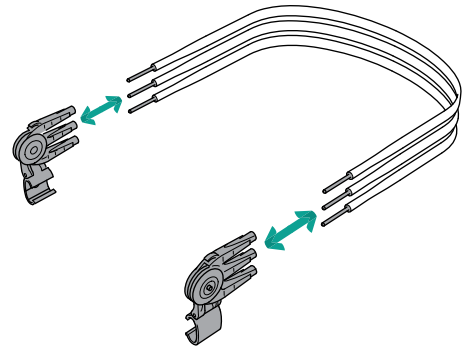
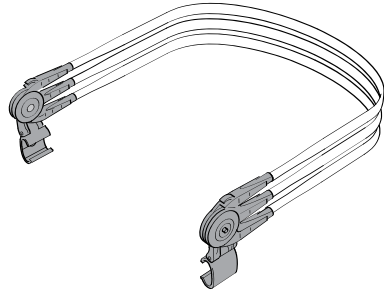

1

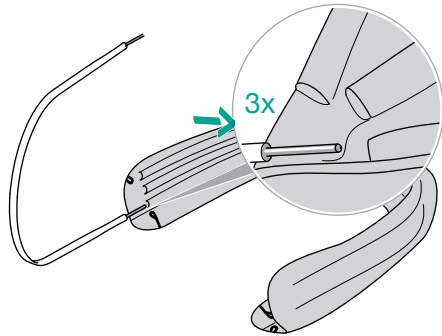

2

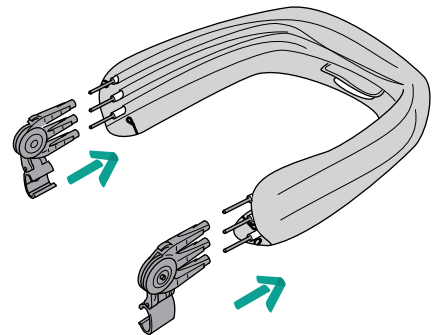

3

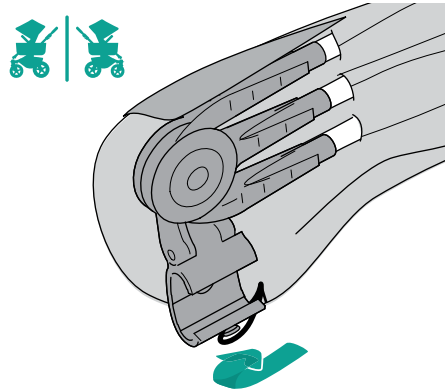

4

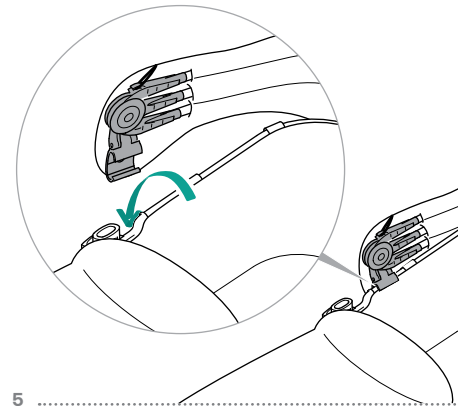

5

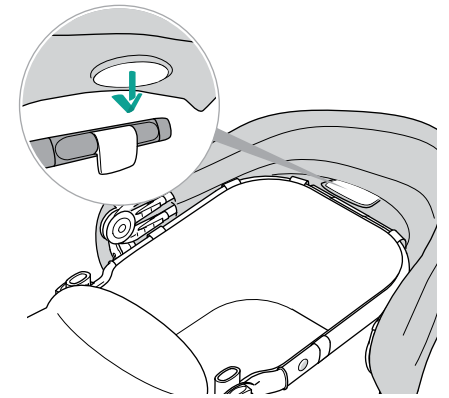

6

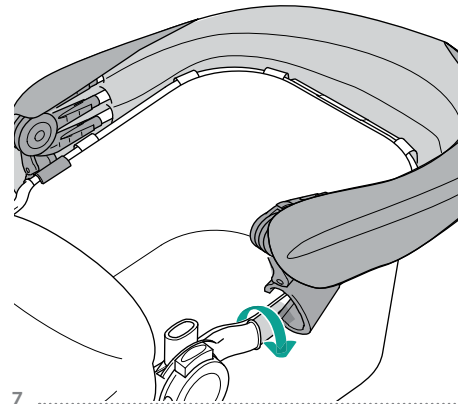

7

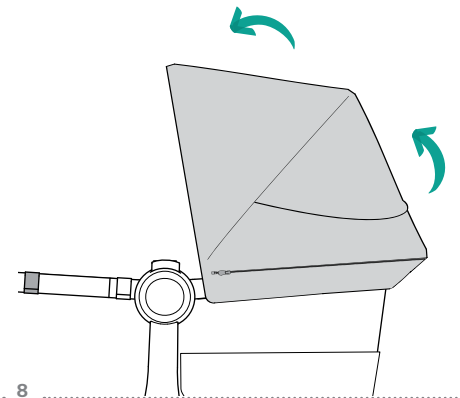

8

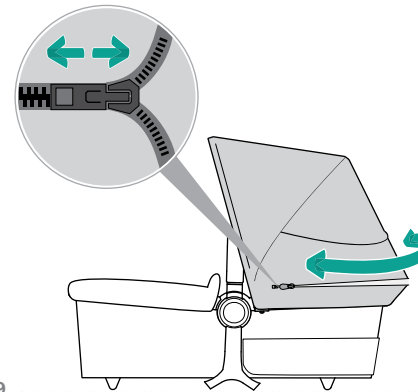

9

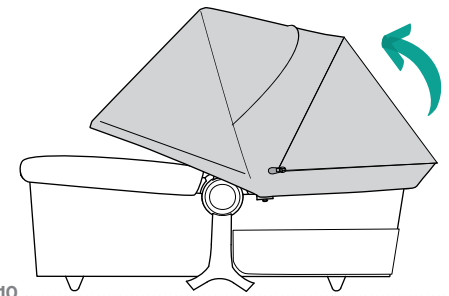

10

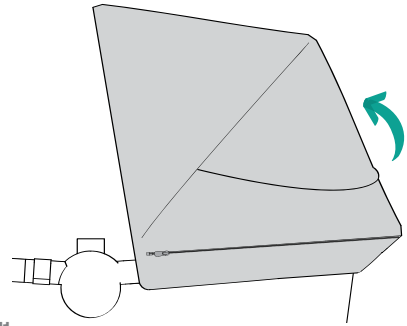

11

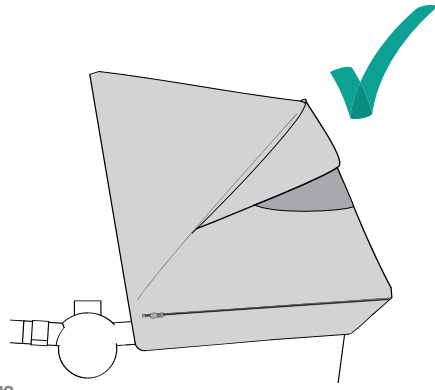

12

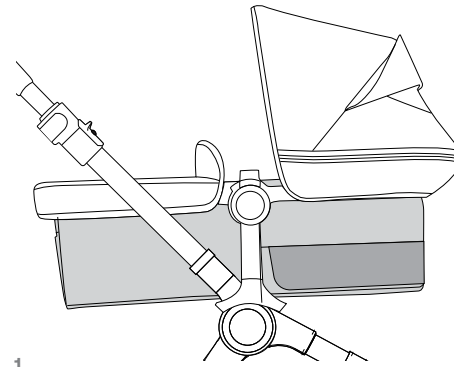

1

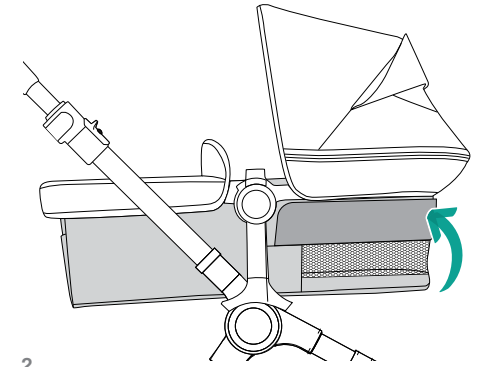

2

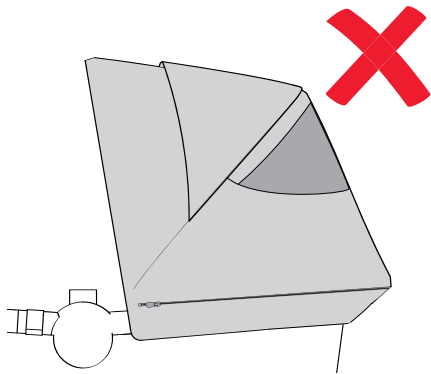

13

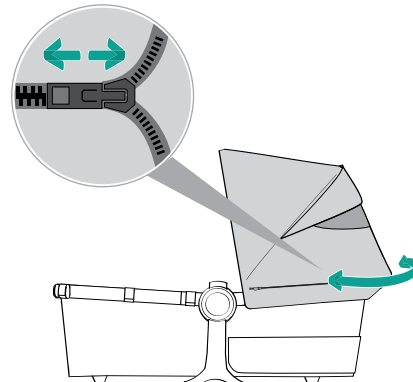

14

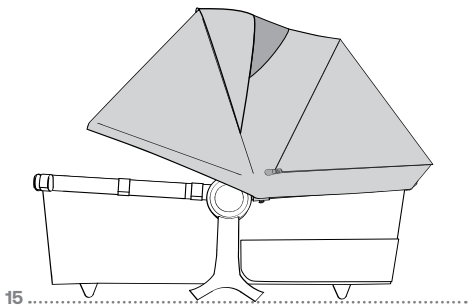

15

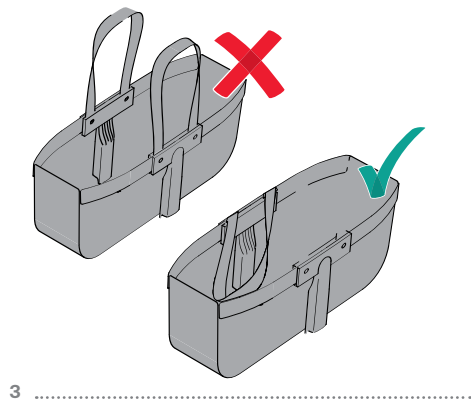
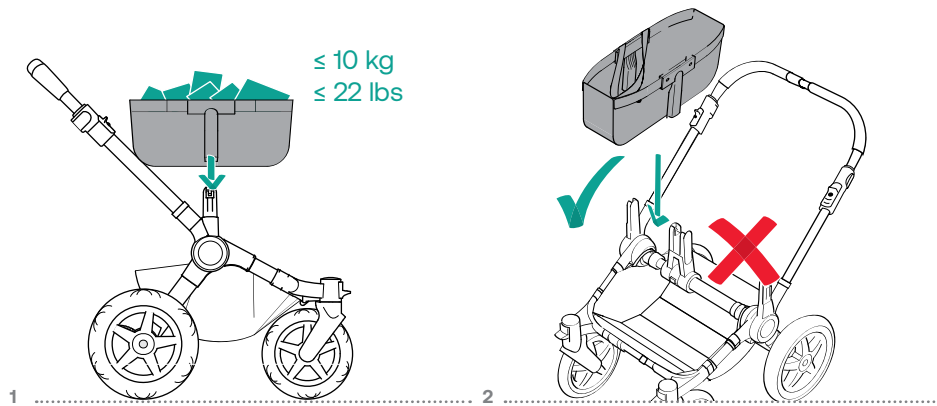

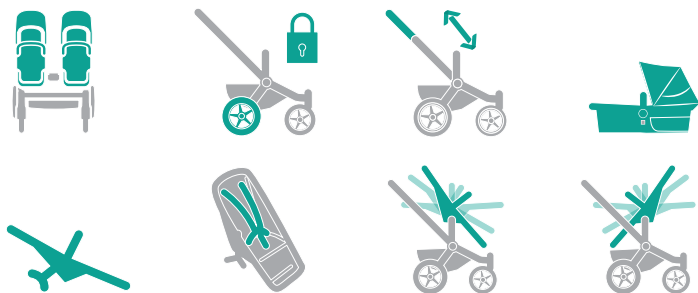

## Features

Please pay extra attention to all the features of the Bugaboo Donkey 5. This enables you to use this product to the fullest and secures a smooth ride for you and your child.

Lees de informatie over alle kenmerken van de Bugaboo Donkey 5 goed door. Zo gebruik je dit product optimaal en ben je verzekerd van een soepele rit voor jou en je kind.

Věnujte prosím speciální pozornost všem funkcím kočárku Bugaboo Donkey 5. To vám umožní využívat tento výrobek naplno a zajistí plynulou jízdu vám i Vašemu dítěti.

Vær ekstra opmærksom på de mange funktioner, som Bugaboo Donkey 5 har. På denne måde får du størst mulig glæde af produktet, og du sikrer en god oplevelse for dig selv og dit barn.

Achten Sie besonders auf all die Produkteigenschaften des Bugaboo Donkey 5. Auf diese Weise können Sie dieses Produkt optimal nutzen und auf sichere Weise für sich und Ihr Kind von den sanften Laufeigenschaften profitieren.

Δώστε ιδιαίτερη προσοχή σε όλα τα χαρακτηριστικά του Bugaboo Donkey 5. Αυτό σας επιτρέπει να χρησιμοποιείτε πλήρως το προϊόν και εγγυάται ευχάριστες βόλτες για εσάς και το παιδί σας.

Por favor, presta especial atención a todas las características del Bugaboo Donkey 5. Esto te permitirá disfrutar de este producto al máximo y te garantizará el paseo más suave para ti y para tu hijo.

Tutustu huolellisesti Bugaboo Donkey 5 -lastenvaunujen monipuolisiin ominaisuuksiin. Siten saat tuotteesta kaiken ilon ja hyödyn irti, ja varmistat mukavan matkanteon itsellesi ja lapsellesi.

Veillez prêter une attention toute particulière aux schémas des fonctionnalités de la Bugaboo Donkey 5. Ils vous permettent d'utiliser le produit au maximum de ses capacités et de garantir une conduite en douceur pour vous et votre enfant.

Presta particolare attenzione a tutte le caratteristiche di Bugaboo Donkey 5. Potrai così usare il prodotto nel migliore dei modi, con una guida fluida che garantisce comfort a te e al tuo bambino.

Vær ekstra oppmerksom på alle funksjonene i Bugaboo Donkey 5. Da får du fullt utbytte av Bugaboo Donkey 5, og både du og barnet får en behagelig tur.

## Features

Zwróć uwagę na wszystkie funkcje wózka Bugaboo Donkey 5. Dzięki temu w pełni wykorzystasz możliwości naszego produktu oraz zapewnisz sobie i swojemu dziecku bezpieczne i płynne poruszanie się.

Execute a ação em ambos os lados do produto. Tenha especial atenção a todas as características do Bugaboo Donkey 5.

Пожалуйста, внимательно ознакомьтесь со всеми функциональными характеристиками коляски Bugaboo Donkey 5. В этом случае вы сможете использовать продукт наиболее полным образом, обеспечив главные поездки вашему ребенку и вам.

Posebej pozorni bodite na vse funkcije vozička Bugaboo Donkey 5. Tako boste lahko v celoti izkoristili ta izdelek ter sebi in svojemu otroku zagotovili nemoteno uporabo.

Var extra uppmärksam på alla funktioner som Bugaboo Donkey 5 erbjuder. Det gör att du kan njuta av produkten till fullo och ger både dig och ditt barn en bättre upplevelse.

Lütfen Bugaboo Donkey 5'nin tüm özelliklerine ekstra özen gösterin. Bu, ürünün en iyi şekilde kullanmanızı sağlayacak olmakla birlikte, sizin ve çocuğunuz için kusursuz bir sürüşe olanak tanıyacaktır.

バグブー ドンキー5に搭載されるすべての機能にご注目ください。ベビーカーを最大限に活用することにより、ご家族全員が安心して楽しめる旅をお約束します。

Bugaboo Donkey 5 제품을 안전하게 사용할 수 있도록 제품의 모든 기능을 반드시 확인해 주십시오.

请特别注意 Bugaboo Donkey 5 的所有功能。这样，您将能够充分使用本产品，并确保您和您的孩子获得顺畅的推乘体验。

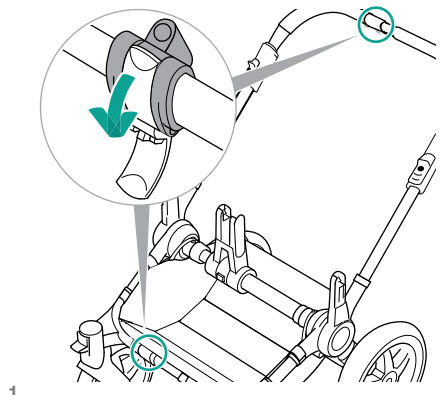
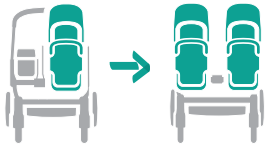

1

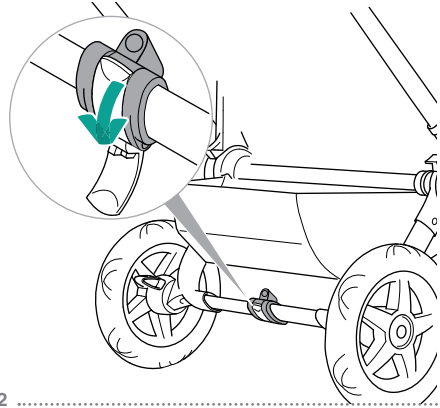

2

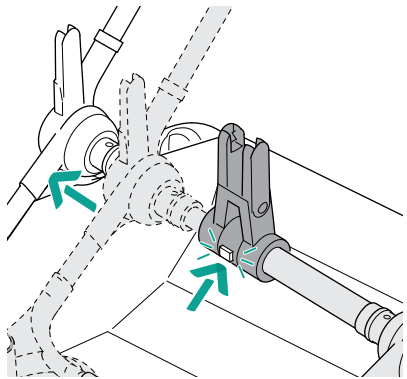

3

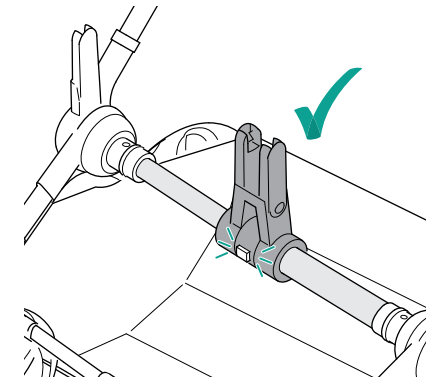

4

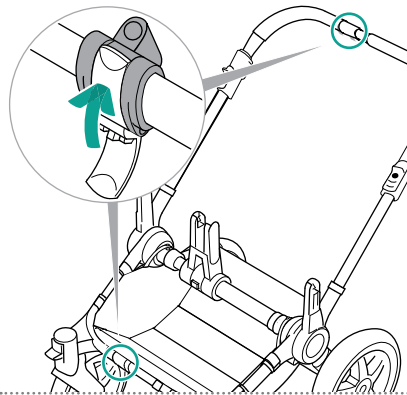

5

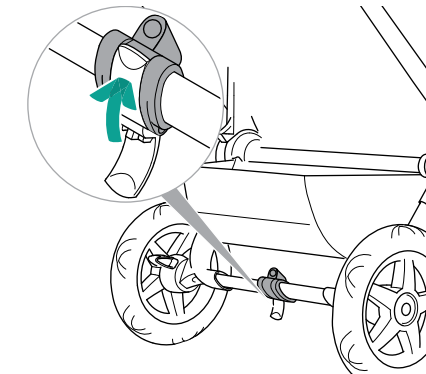

6

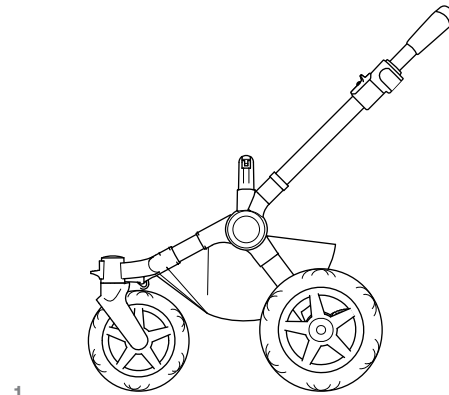

1

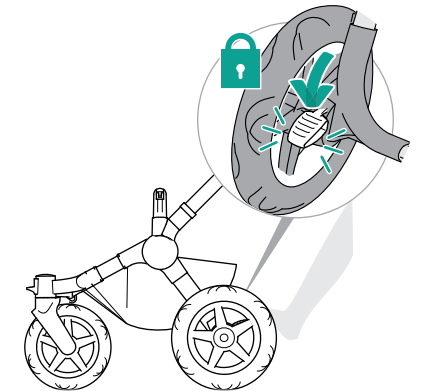

2

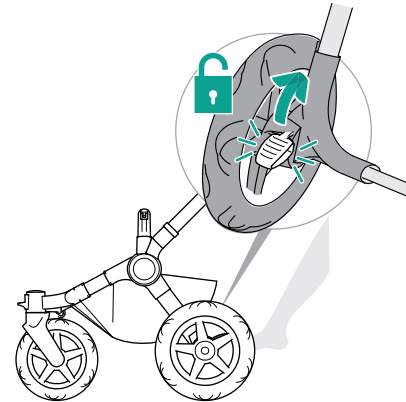

3

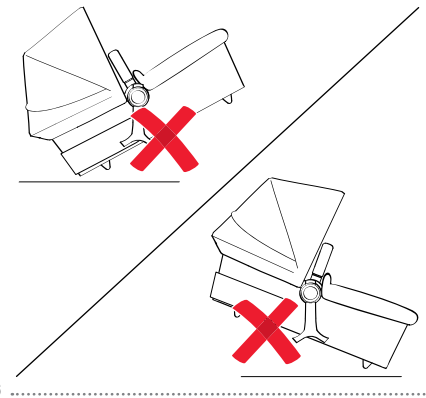
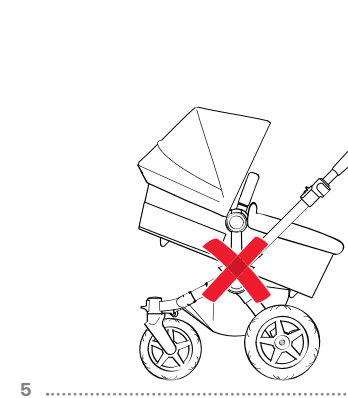
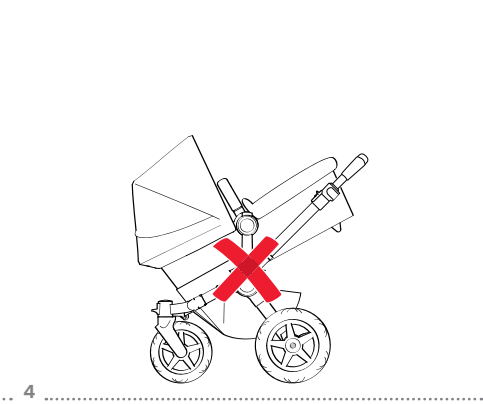
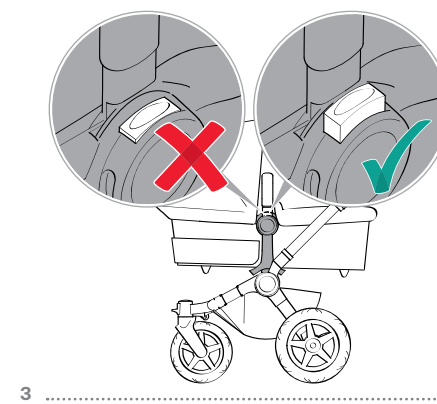
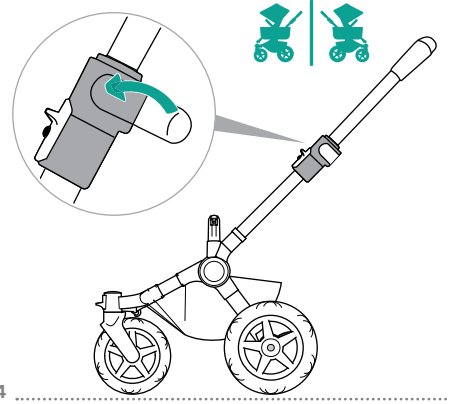
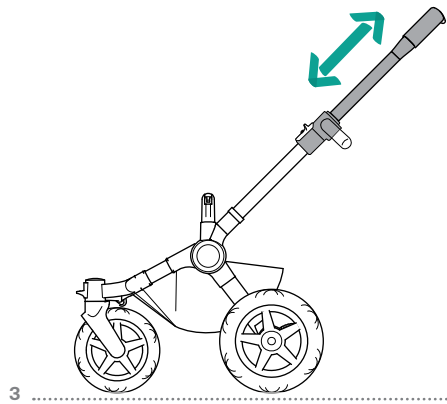
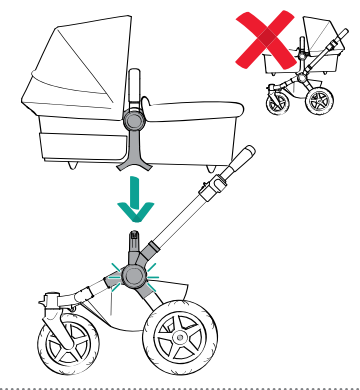
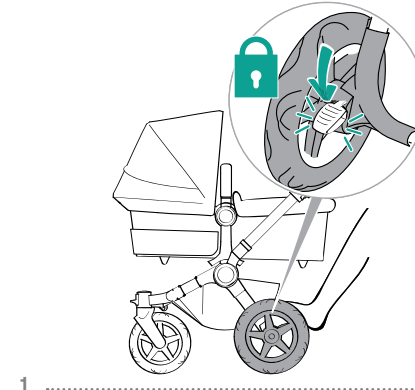
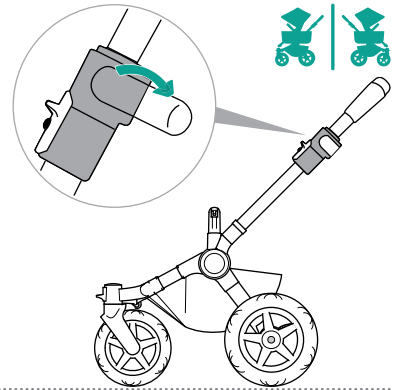
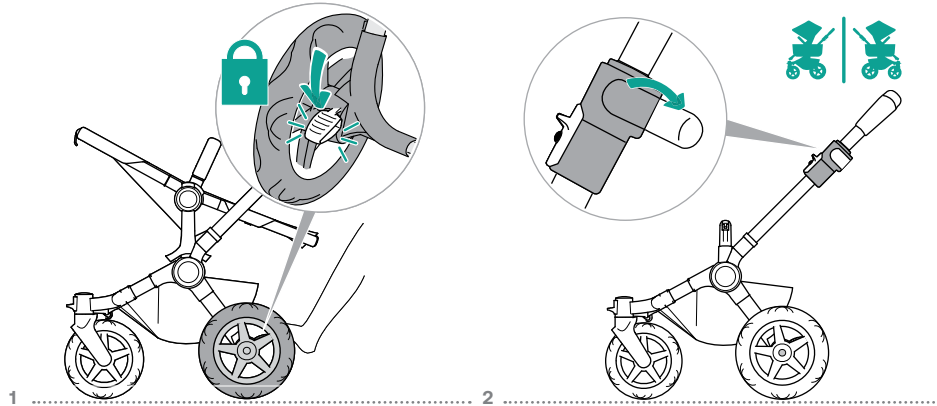

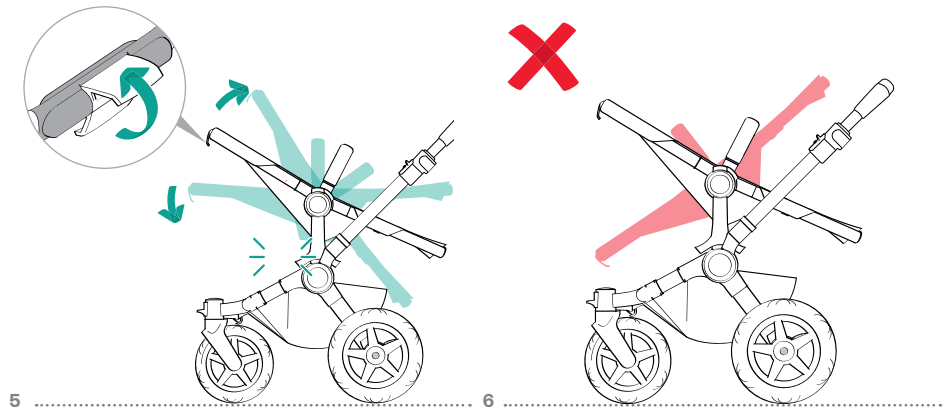
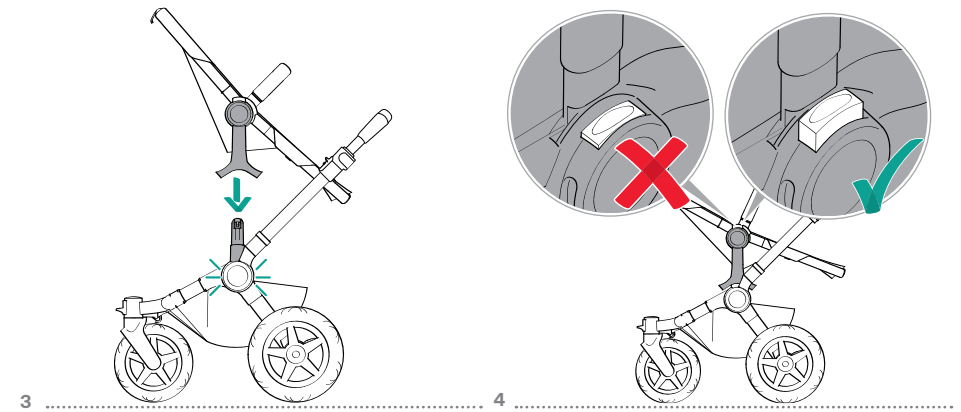
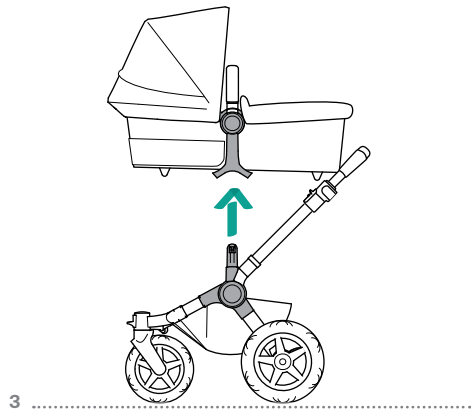
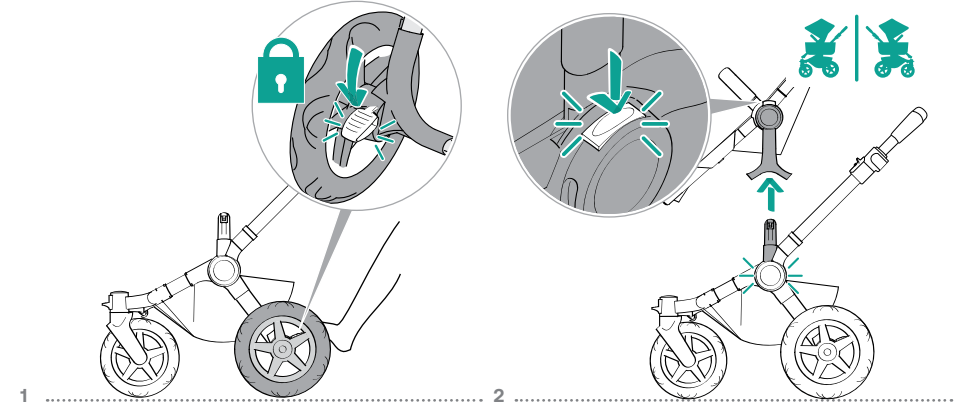
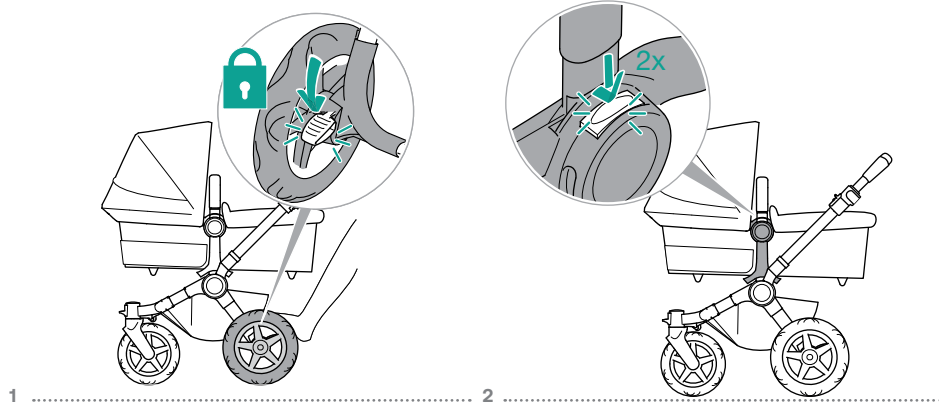
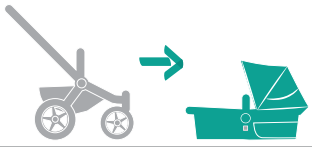

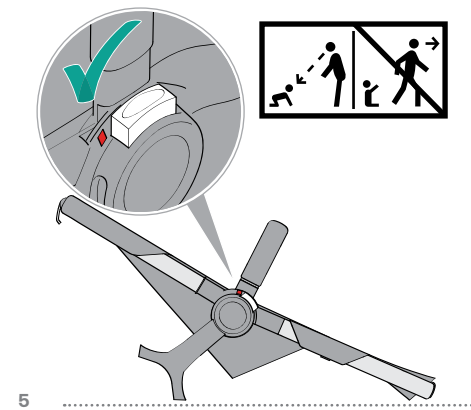
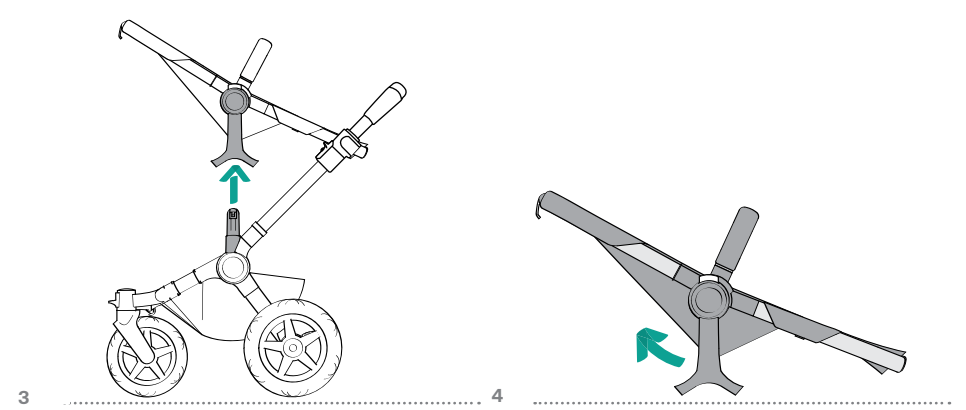
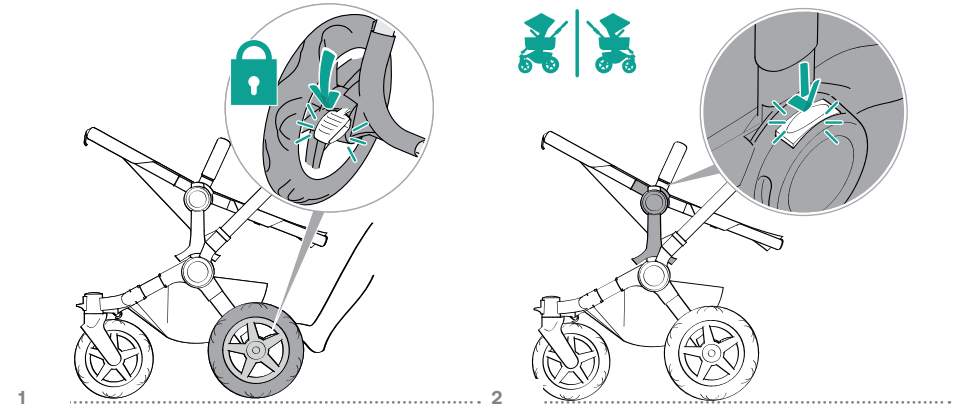
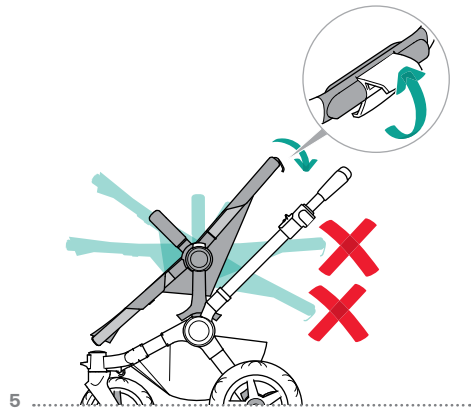
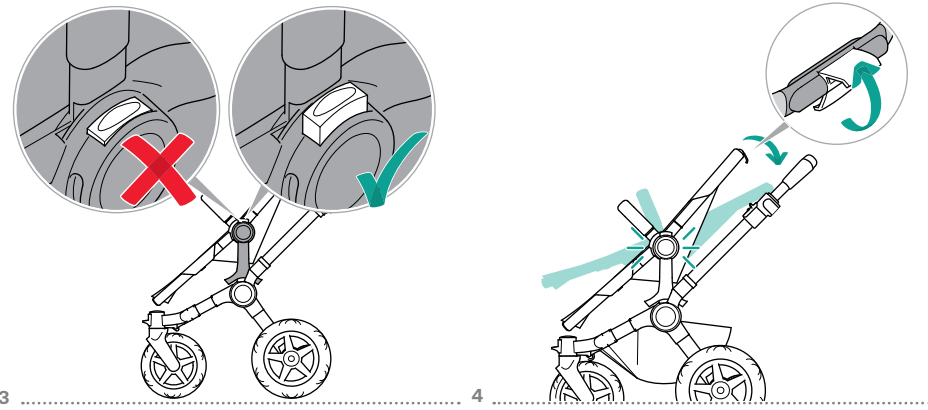
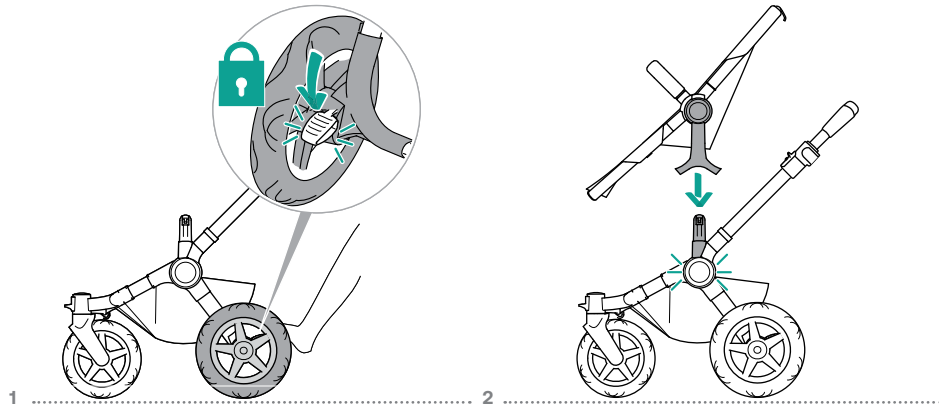

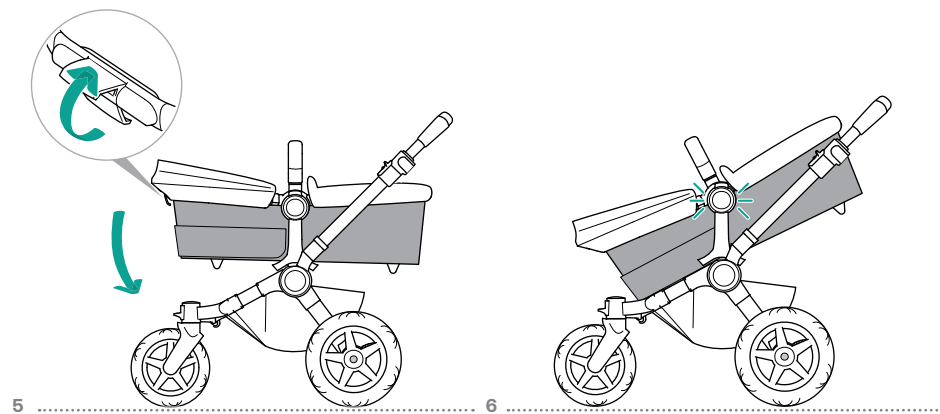
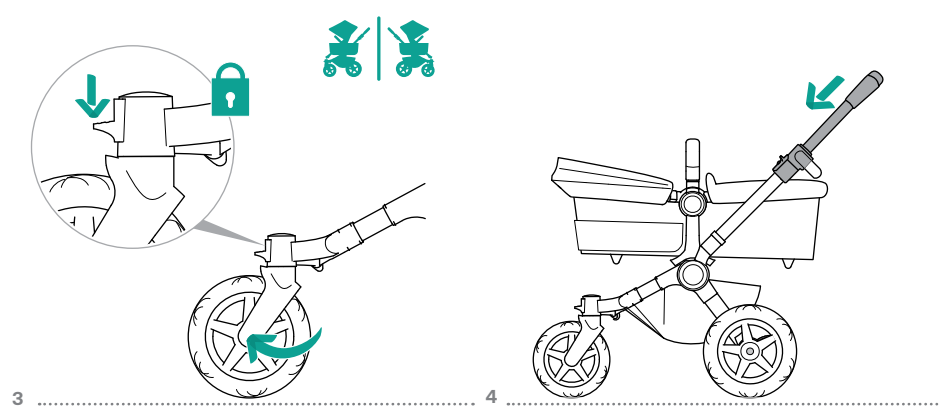
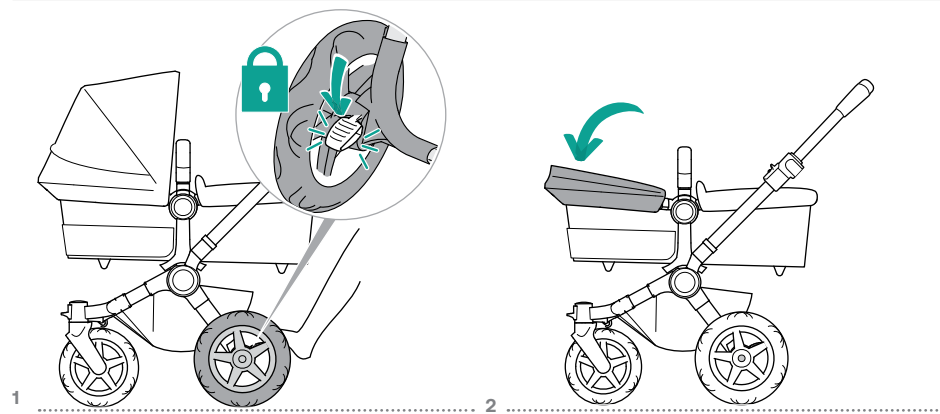
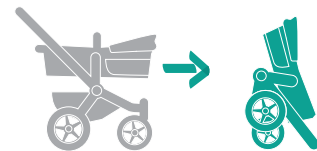
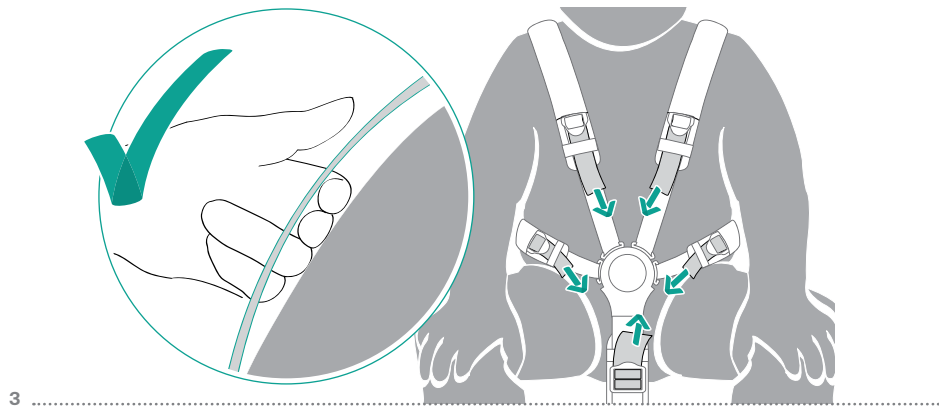
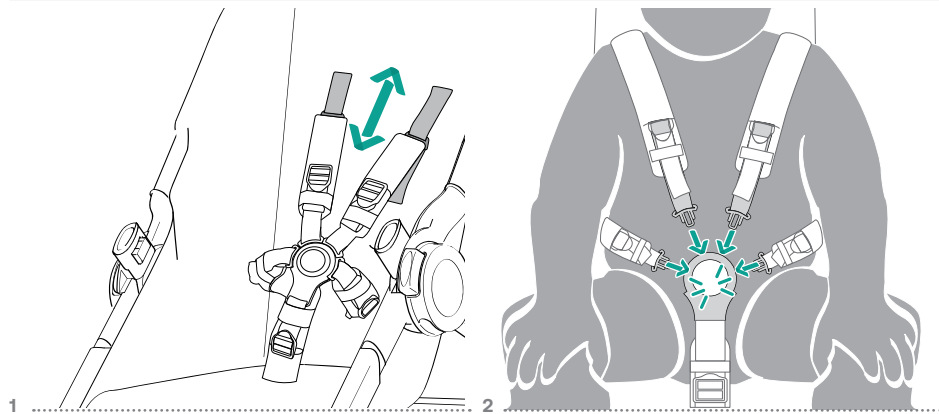

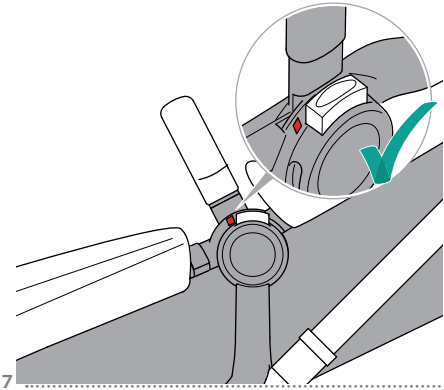

7

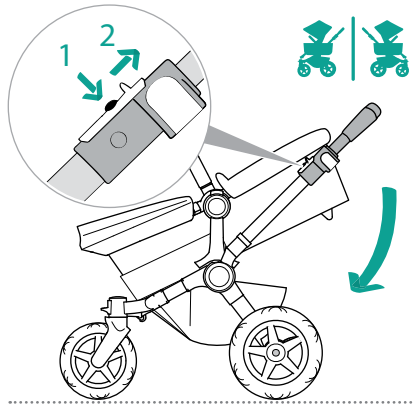

8

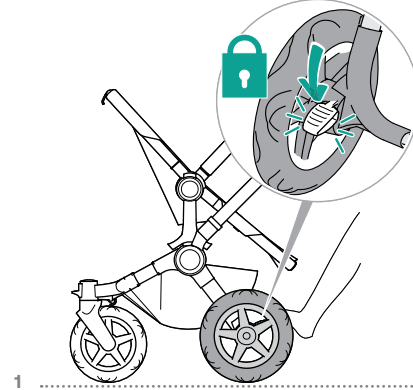

1

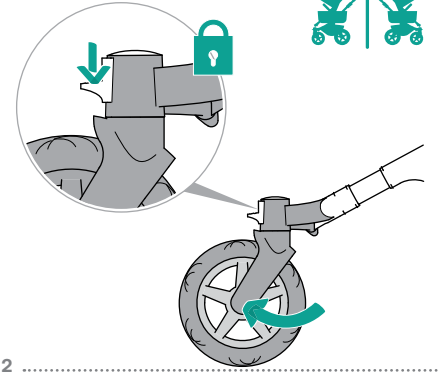

2

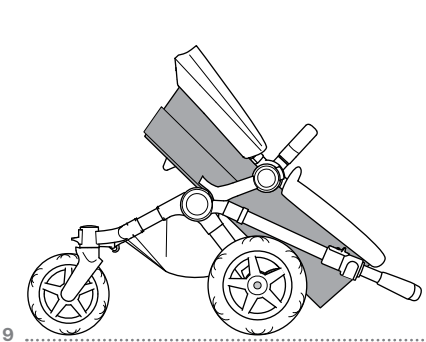

9

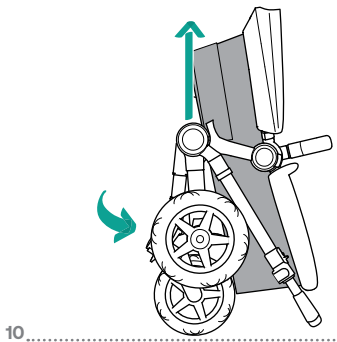

10

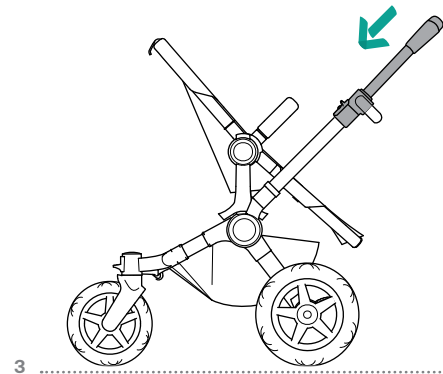

3

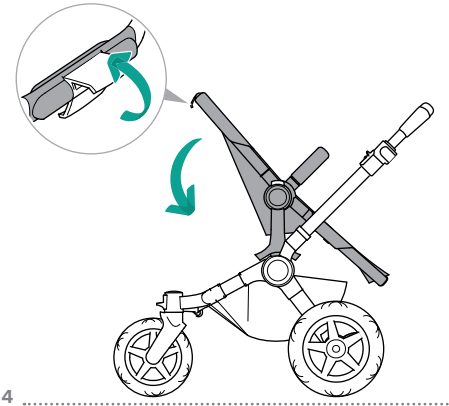

4

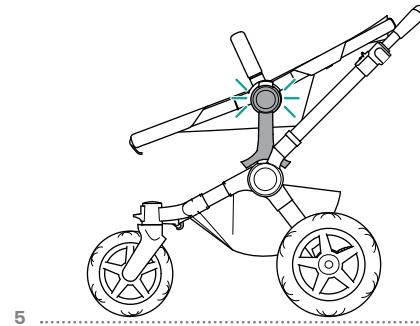

5

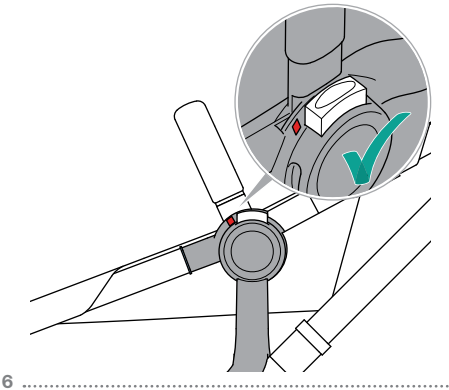

6

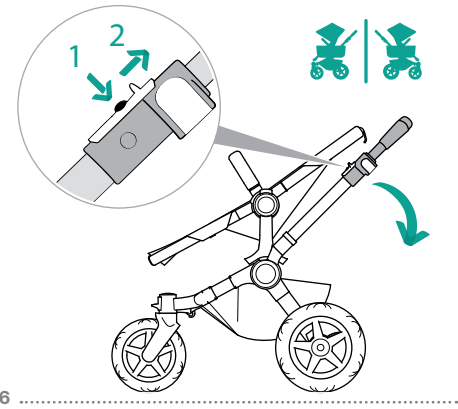
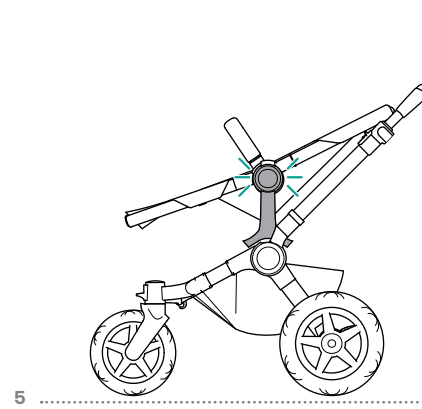
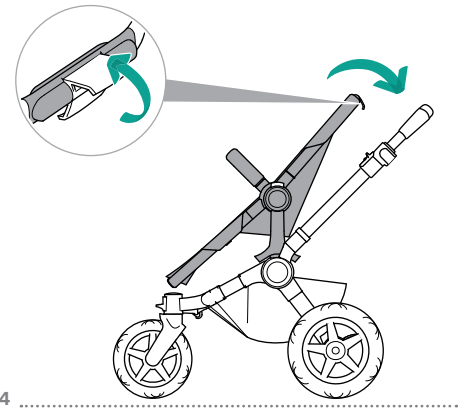
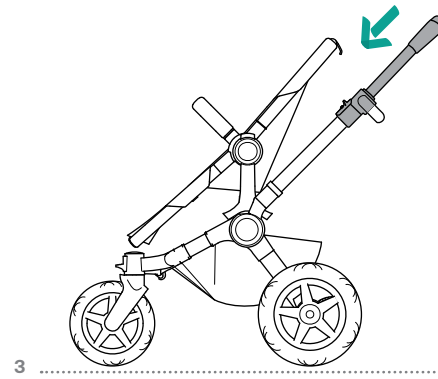
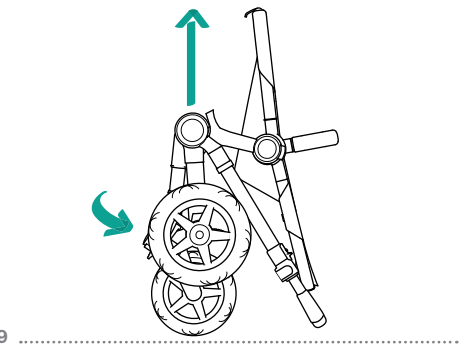
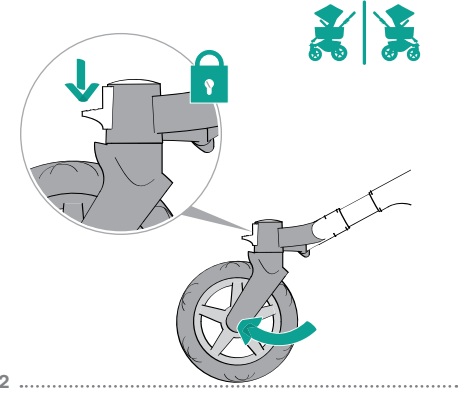
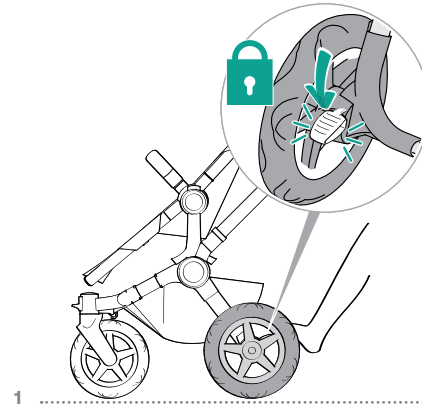
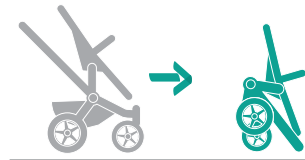
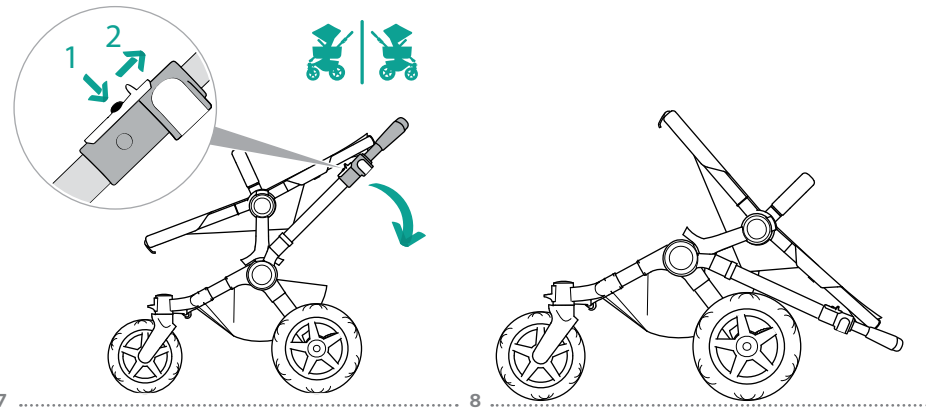

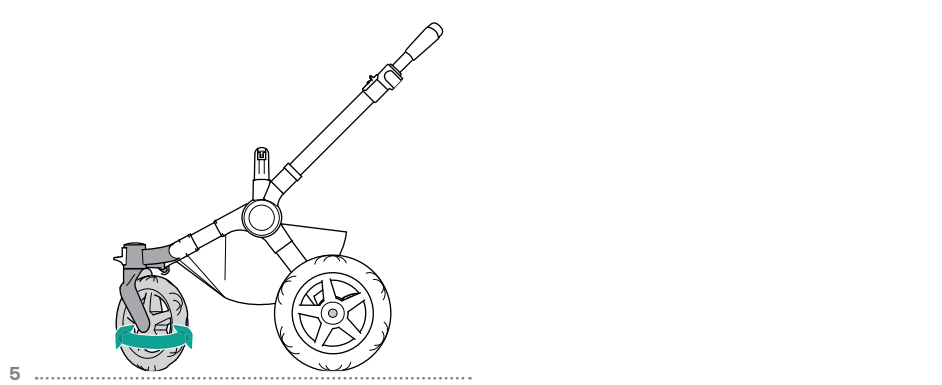
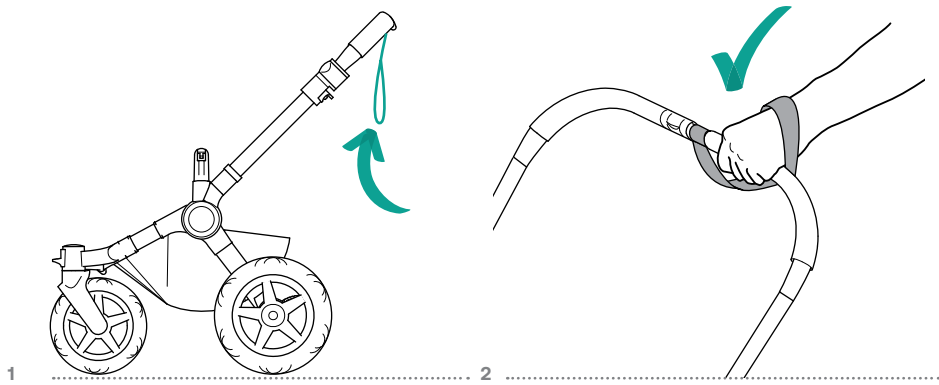
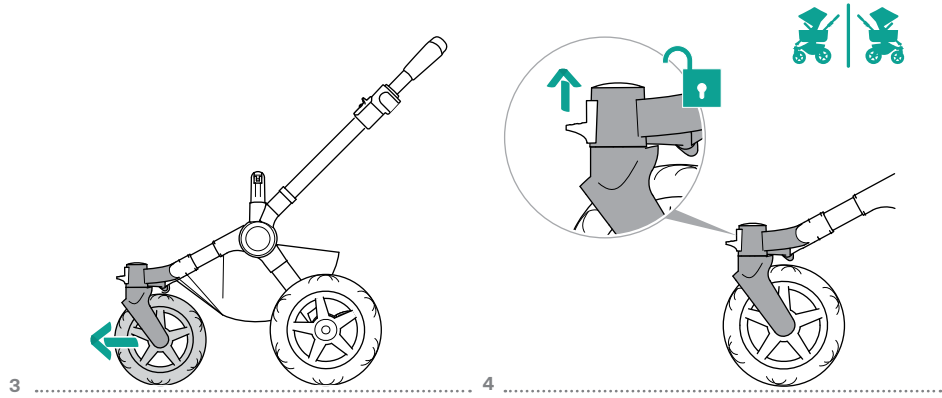
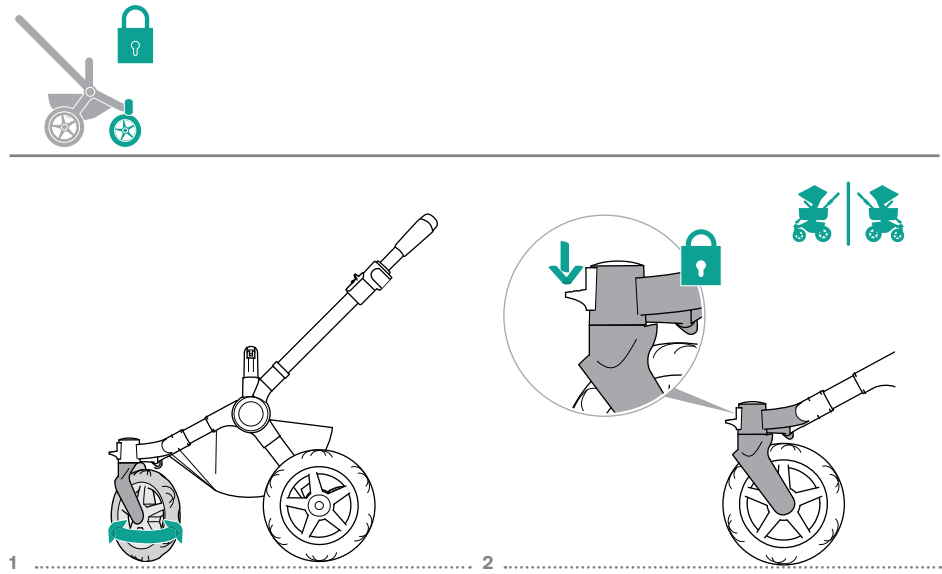
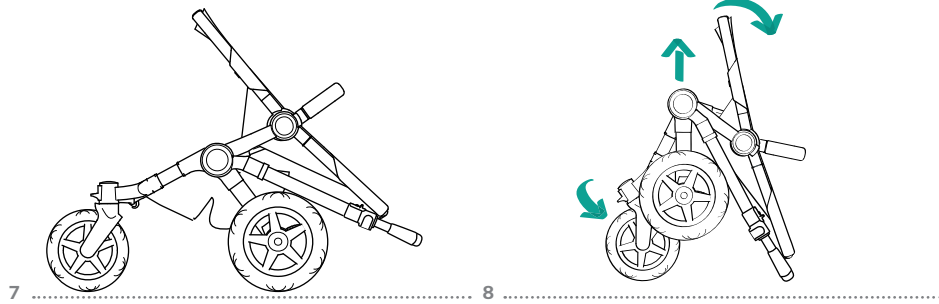

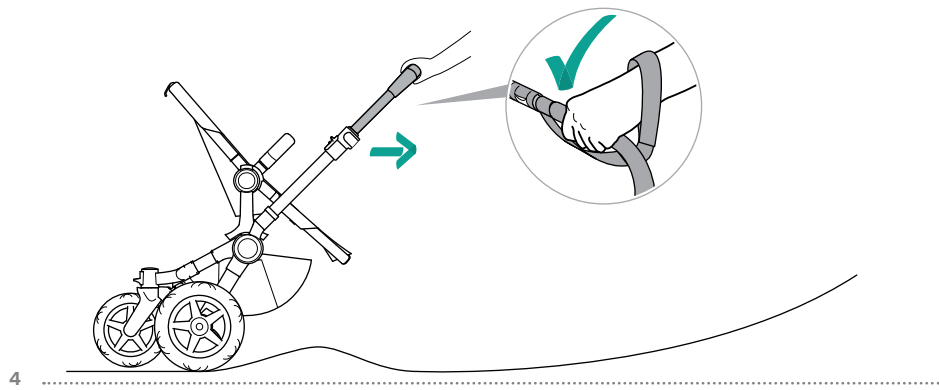
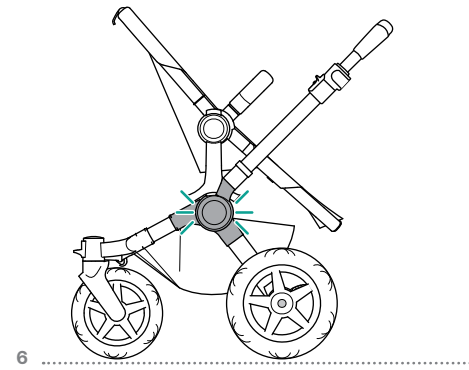
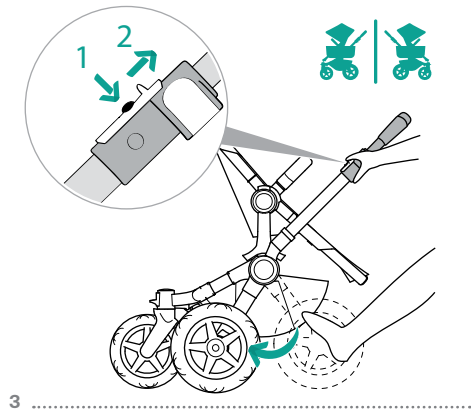
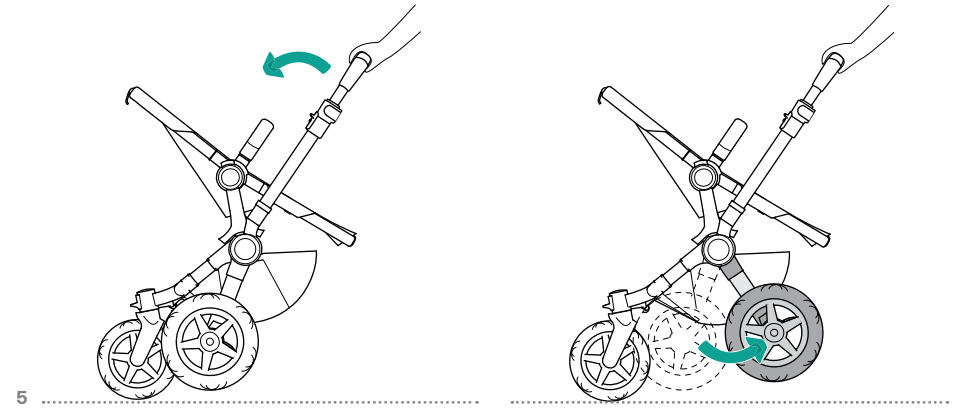
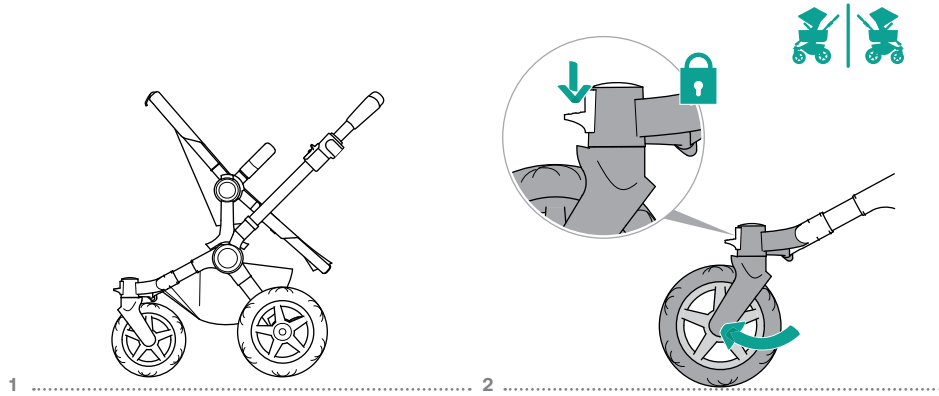

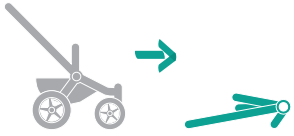

\* Only available in Australia

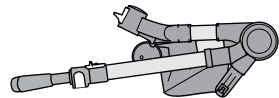
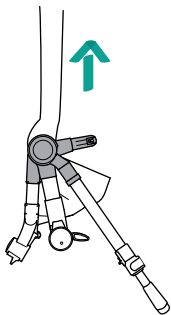
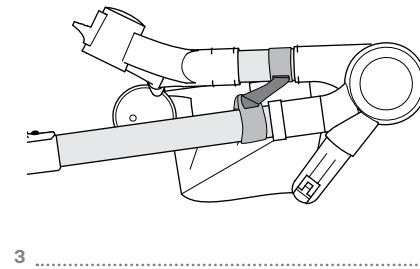
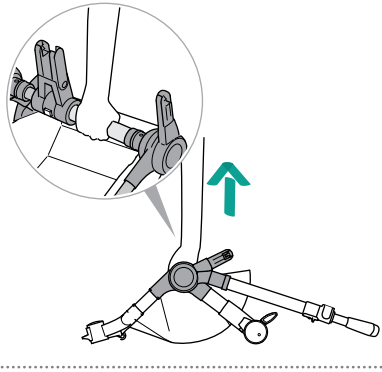
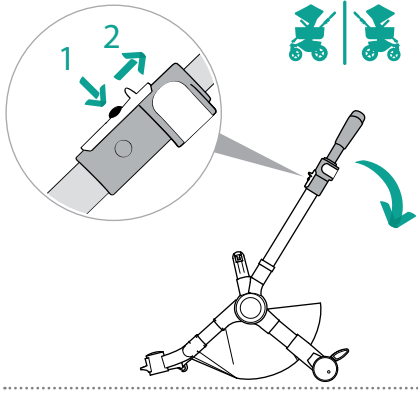
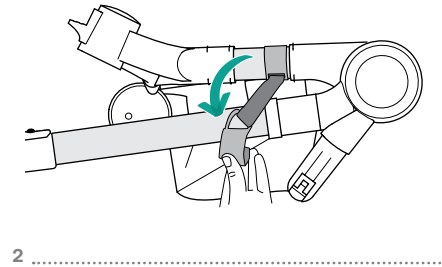
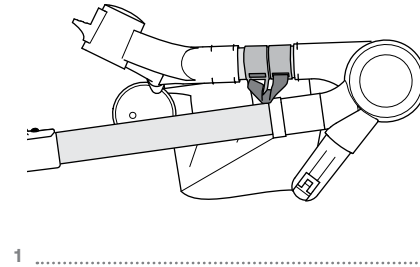
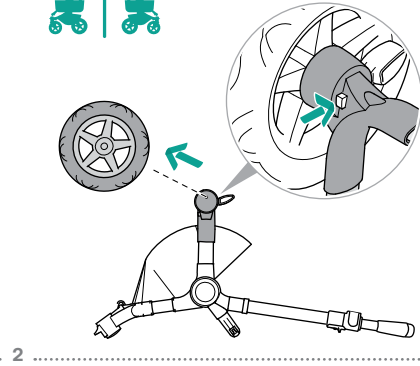
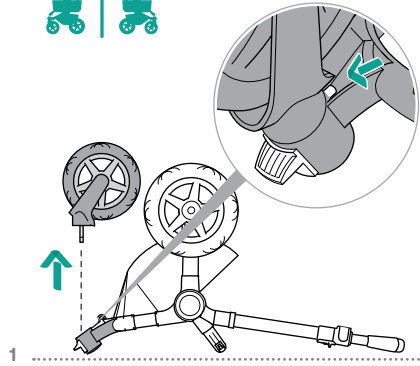

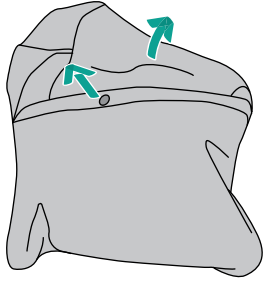

1

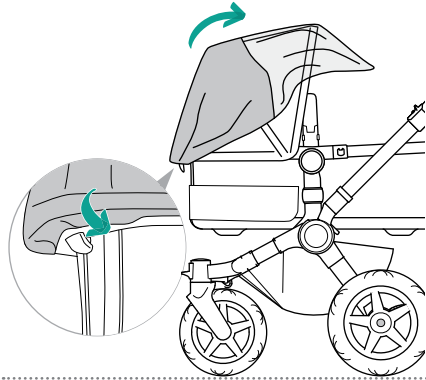

2

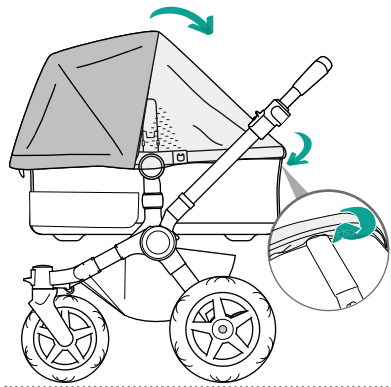

3

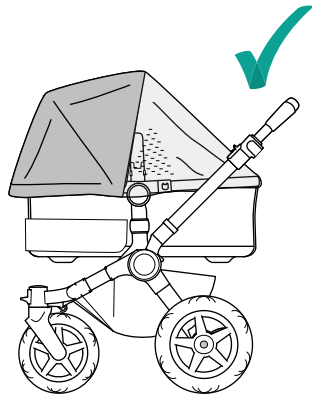

4

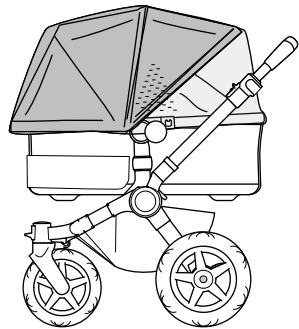

5



6

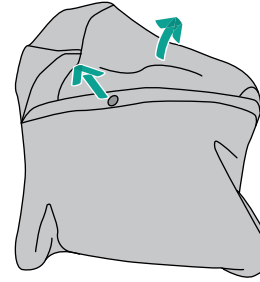
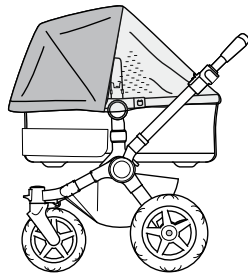

1

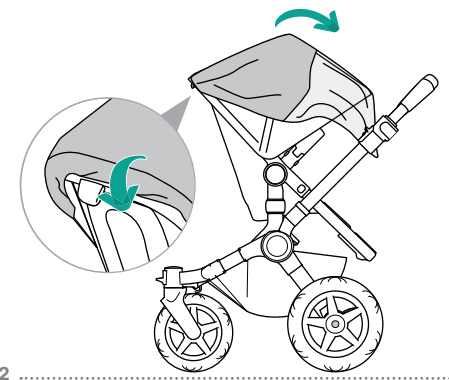

2

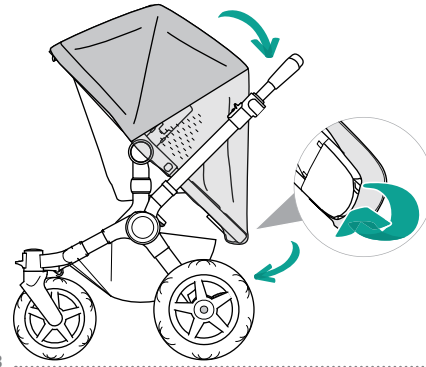

3

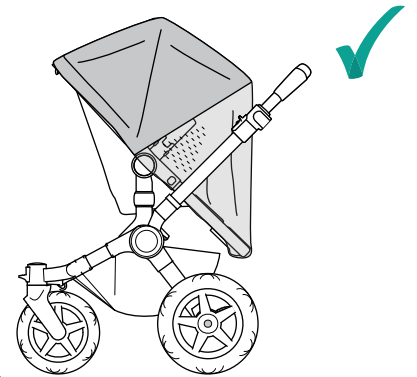

4

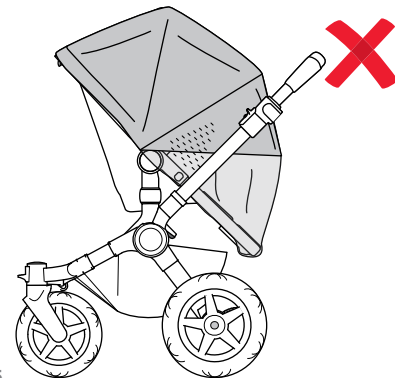

5



6

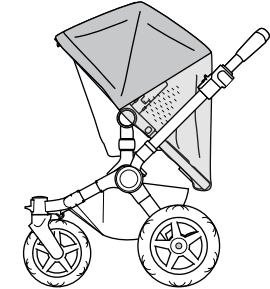

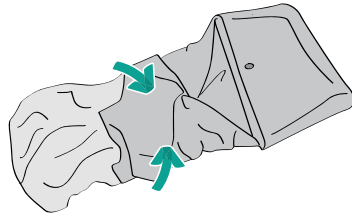
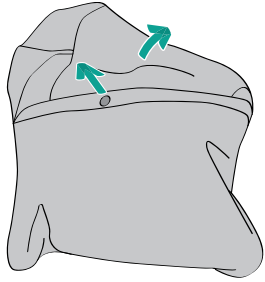

7 ..... 8

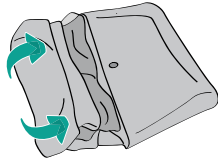
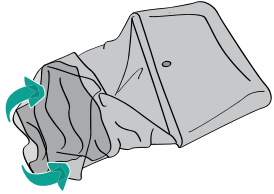

9 ..... 10

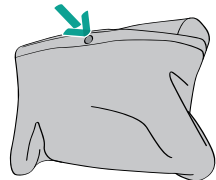
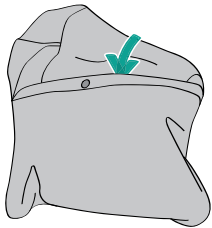

11 ..... 12

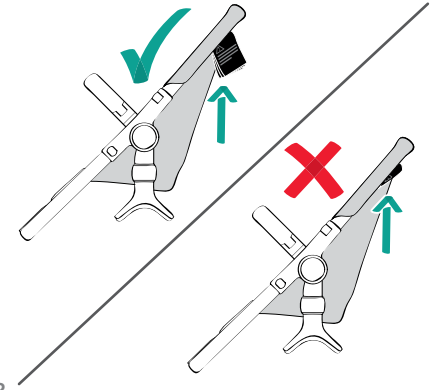
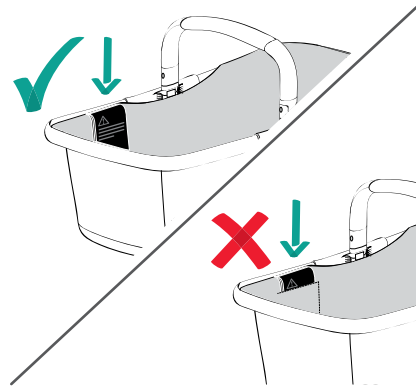

1 ..... 2

The information contained herein is subject to change without notice. Bugaboo International BV shall not be liable for technical errors or omissions contained herein. The purchased product may differ from the product as described in this user guide. Our most recent user guides can be requested at our service departments or at [www.bugaboo.com](http://www.bugaboo.com).

© 2021 Bugaboo International BV. BUGABOO, BUGABOO CAMELEON, BUGABOO BEE, BUGABOO DONKEY, BUGABOO FOX, BUGABOO TURTLE, BUGABOO ANT, BUGABOO LYNX, BUGABOO STARDUST, BUGABOO BUTTERFLY and the Bugaboo logos are registered trademarks. The Bugaboo® strollers are patented and design protected.



**Bugaboo Europe & Asia**

Bugaboo International B.V.  
Paasheuvelweg 9 a-b  
1105 BE Amsterdam Zuidoost  
The Netherlands

**Bugaboo UK Limited (07785001)**

Unit 3 & 4 Riverside Barns  
Remenham Lane  
Remenham, Henley-On-Thames  
RG9 3DB  
England

**Bugaboo Russia**

ООО Бугабу Рус, 121471,  
улица Рябиновая, дом 26, стр.1  
город Москва  
Россия

**Bugaboo North America, Inc.**

142 W 57th St New York  
New York 10019  
United States of America

**Bugaboo Australia**

Bugaboo Australia Pty Limited  
Service department Suite 2, Level 2  
156 Edgecliff Road Woollahra, NSW 2025  
Australia

**Bugaboo Japan K.K.**

100-0004  
SPACES大手町  
大手町1-6-1 大手町ビル1階  
東京都千代田区  
Japan

**Bugaboo Korea Co., Ltd.**

부가부코리아(유)  
서울특별시  
송파구 오금로 97  
방이동, 진넥스빌딩 8층  
1577-0680  
Korea

**Bugaboo Shanghai Co., Ltd.**

博各步贸易（上海）有限公司  
上海市崇明区长兴镇潘园公路1800号3号楼  
62889室  
China