

meet your bugaboo fox²

ontdek jouw bugaboo²

sig hej til din bugaboo fox²

entdecken Sie den bugaboo fox²

γνωρίστε το bugaboo fox² σας

conoce tu bugaboo fox²

esittelyssä bugaboo fox²

découvrez la bugaboo fox²

ecco il tuo bugaboo fox²

møt din bugaboo fox²

poznaj swój bugaboo fox²

descubra o bugaboo fox²

познакомьтесь с вашей коляской bugaboo fox²

spoznajte svoj bugaboo fox²

Säg hej till din bugaboo fox²

meet your bugaboo fox² ile tanışma

bugaboo fox² の各部の名前

bugaboo fox² 를 만나 보세요

欢迎使用 bugaboo fox²

שלכם bugaboo fox² הכירו את

fox²

bugaboo

parts for set-up

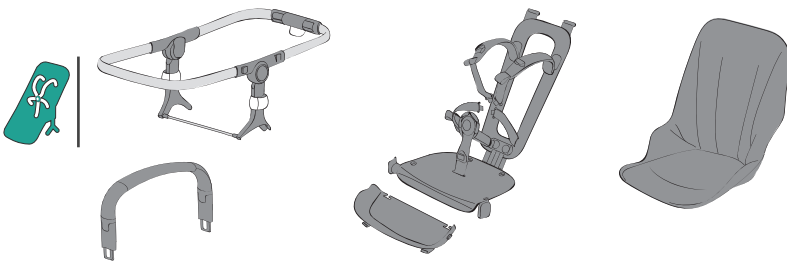
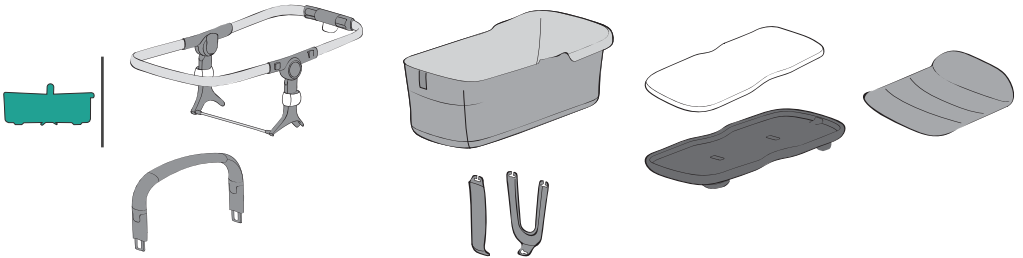
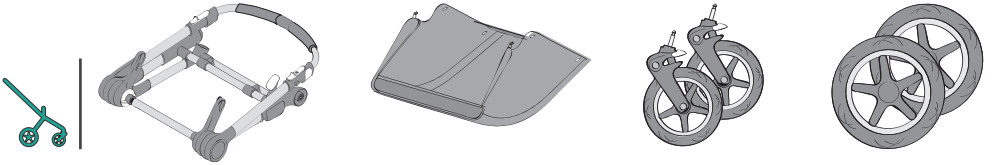

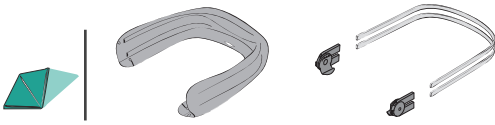

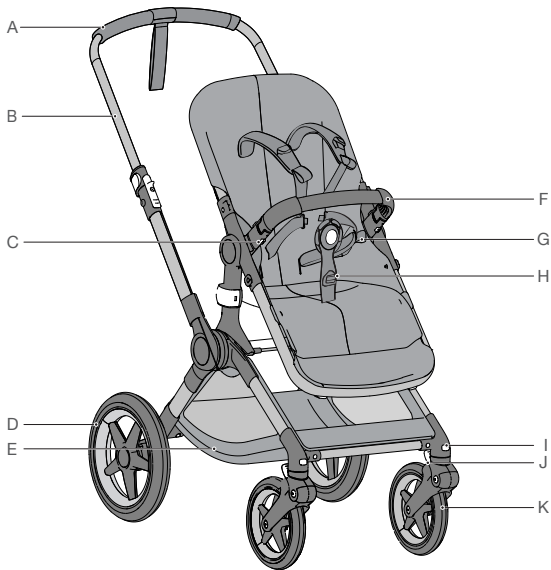

* product depicted may not be exactly the same in all regions

en|

- A. handlebar
- B. chassis
- C. carry handle release button
- D. large wheel
- E. underseat bag
- F. carry handle
- G. seat
- H. harness
- I. swivel wheel release button
- J. swivel wheel lock
- K. swivel wheel

- L. integrated attachment point 1
- M. wrist strap
- N. apron
- O. handlebar adjustment clip
- P. integrated attachment point 2
- Q. bassinet stiffener
- R. bassinet/carrycot/pram body
- S. brake
- T. integrated attachment point 3
- U. large wheel release button
- V. sun canopy

- W. square white knob
- X. unfolding lock
- Y. suspension

nl	A. duwbeugel	L. bevestigingspunt 1	wiel
	B. onderstel	M. polsband	V. zonnekap
	C. draagbeugel-ontgrendelingsknop	N. wiegdekje	W. vierkante witte knop
	D. groot wiel	O. verstellklemmen voor de duwbeugel	X. vergrendeling
	E. bagagetas	P. bevestigingspunt 2	Y. vering
	F. draagbeugel	Q. versteviger voor wieg	
	G. stoel	R. wieg	
	H. harnas	S. rem	
	I. ontgrendelingsknop zwenkwielen	T. bevestigingspunt 3	
	J. zwenkwielblokkeerder	U. ontgrendelingsknop voor groot	
	K. zwenkwiel		

cs	A. rukojeť	L. úchytný bod 1	V. hranatý bílý knoflík
	B. podvozek	M. popruh na zápěstí	X. odepnutí uzamknutí
	C. tlačítko k uvolnění držadla	N. přenosná taška	Y. odpružení
	D. velké kolo	O. svorky pro nastavení rukojeti	
	E. taška pod sedačku	P. úchytný bod 2	
	F. držadlo	Q. výztuha hlubokého lůžka	
	G. sedačka	R. příkrývka přenosné tašky	
	H. popruhy	S. výztuha	
	I. tlačítko pro uvolnění otočných kol	T. úchytný bod 3	
	J. otočný zámek	U. tlačítko k uvolnění velkého kola	
	K. otočné kolo	V. stříška kočárku	

da	A. styr	L. påmonteringspunkt 1	V. firkantede hvide knapper
	B. understel	M. håndledsrem	X. udfoldningslås
	C. knap til frigørelse af bærehåndtag	N. lift	Y. fjedring
	D. store hjul	O. justeringsclips til styr	
	E. taske under sædet	P. påmonteringspunkt 2	
	F. bærehåndtag	Q. Stiver til lift	
	G. sæde	R. lift overdække	
	H. seler	S. bremse	
	I. knap til frigørelse af styrehjul	T. påmonteringspunkt 3	
	J. styrehjullås	U. udløserknap for store hjul	
	K. svinghjul	V. sommerkaleche	

de	A. schiebebügel	L. befestigungspunkt 1	rades
	B. gestell	M. sicherheitsriemen für das handgelenk	V. sonnendach
	C. tragebügel-entriegelungsknopf	N. liegeaufsatz	W. quadratische weiße knopf
	D. großes rad	O. schiebebügel-einstellclips	X. auseinanderklapp-sperre
	E. untergestell-tasche	P. befestigungspunkt 2	Y. federung
	F. tragebügel	Q. streben für den Liegeaufsatz	
	G. sitz	R. winddecke	
	H. sicherheitsgurte	S. bremse	
	I. schwenkrad-feststellknopf	T. befestigungspunkt 3	
	J. schwenkradverriegelung	U. entriegelungsknopf des großen	
	K. schwenkrad		

el	A. χειρολαβή	J. ασφάλεια περιστρεφόμενου τροχού	S. φρένο
	B. βάση	K. περιστρεφόμενος τροχός	T. σημείο στερέωσης 3
	C. μπουτόν απελευθέρωσης χερουλιού μεταφοράς	L. σημείο στερέωσης 1	U. κουμπιί απελευθέρωσης μεγάλου τροχού
	D. μεγάλος τροχός	M. περικάρπιο	V. τέντα ηλίου
	E. σάκος κάτω από το κάθισμα	N. πορτ-μπεμπέ (καλάθι)	W. τετράγωνο λευκό μπουτόν
	F. χερούλι μεταφοράς	O. κλιπ προσαρμογής χειρολαβής	X. αναδιπλούμενη ασφάλεια
	G. κάθισμα	P. σημείο στερέωσης 2	Y. ανάρτηση
	H. ζώνη	Q. ενισχυτικό έλασμα πορτ-μπεμπέ	
	I. κομβίιο απελευθέρωσης περιστρεφόμενου τροχού	R. ποδιά πορτ-μπεμπέ (ποδιά καλαθίου)	

es	A. manillar	J. bloqueo de ruedas giratorias	T. punto de enganche 3
	B. chasis	K. rueda giratoria	U. botón de desenganche de las ruedas grandes
	C. botón de apertura del asa de transporte	L. punto de enganche 1	V. capota
	D. rueda grande	M. muñequera de seguridad	W. boton cuadrado blanco
	E. cesta de compras	N. capazo	X. seguro de desplegado
	F. asa de transporte	O. abrazaderas del manillar extensible	Y. suspensión
	G. silla	P. punto de enganche 2	
	H. arnés	Q. lengüeta del capazo	
	I. botón de desenganche de rueda giratoria	R. cubrepies	
		S. freno	

fi	A. työntöaisa	K. kääntyvä pyörä	V. suojakuomu
	B. runko	L. kiinnityskohta 1	W. neliskulmainen valkoinen nappi
	C. kantokahvan vapautuspainike	M. käsilenkki	X. avausalpa
	D. isot pyörät	N. vaunukoppa	Y. jousitus
	E. istuinkori	O. työntöaisan säätökiinnittimet	
	F. kantokahva	P. kiinnityskohta 2	
	G. istuin	Q. vaunukopan jäykistin	
	H. valjaat	R. vaunukopan peite	
	I. kääntyvien pyörien vapautusnäppäin	S. jarru	
	J. kääntyvien pyörien lukko	T. kiinnityskohta 3	
		U. ison pyörän vapautusnäppäin	

fr	A. guidon	J. bouton de verrouillage de la roue pivotante	T. point de fixation 3
	B. châssis	K. roue pivotante	U. bouton de déverrouillage de la grosse roue
	C. bouton de déverrouillage de la poignée	L. point de fixation 1	V. capote
	D. grosse roue	M. dragonne de poignet	W. boutons blancs carrés
	E. panier	N. nacelle	X. bouton de dépliage
	F. poignée	O. clips d'ajustement du guidon	Y. suspension
	G. siège	P. point de fixation 2	
	H. harnais	Q. armature de la nacelle	
	I. bouton de déverrouillage de la roue pivotante	R. tablier de nacelle	
		S. frein	

it	A. manubrio	K. ruota piroettante	grande
	B. telaio	L. punto di installazione 1	V. capottina
	C. pulsante di rilascio manubrio	M. cinghia da polso	W. pulsanti quadrati bianchi
	D. ruota grande	N. navetta	X. blocco di apertura
	E. borsa portaoggetti	O. clip per la regolazione del manubrio	Y. molleggio
	F. manico	P. punto di installazione 2	
	G. seggiolino	Q. elementi di rinforzo della navicella	
	H. cintura di sicurezza	R. coperta navetta	
	I. pulsante di sblocco ruote piroettanti	S. freno	
	J. blocco ruote piroettanti	T. punto di installazione 3	
		U. pulsante di sblocco della ruota	

no	A. styre	L. festepunkt 1	V. firkantet hvit knapp
	B. understell	M. håndleddbånd	X. felle opp lås
	C. utløsningsknapp for bærehåndtak	N. bag	Y. fjæring
	D. stort hjul	O. justeringsklips for styre	
	E. bagasjeveske	P. festepunkt 2	
	F. bærehåndtak	Q. bagavstiver	
	G. sete	R. overtrekk	
	H. sele	S. bremse	
	I. retningslås for svinghjul	T. festepunkt 3	
	J. retningslås for svinghjul	U. frigjøringsknapp for store hjul	
	K. svinghjul	V. kalesje	

pl	A. rączka	L. miejsce przyłączenia 1	W. kwadratowy biały przycisk
	B. podwozie	M. pasek na nadgarstek	X. blokada rozkładania
	C. przycisk do zwalniania rączki	N. gondola	Y. zawieszenie
	D. duże koło	O. klamry do regulacji rączki	
	E. torba pod siedzenie	P. miejsce przyłączenia 2	
	F. rączka do przenoszenia	Q. usztywniacz gondoli	
	G. siedzenie	R. przykrycie gondoli	
	H. szelki	S. hamulec	
	I. przycisk do kół zwrotnych	T. miejsce przyłączenia 3	
	J. zamek zwrotny	U. przycisk do zwalniania dużych kół	
	K. koło zwrotne	V. budka przeciwsłoneczna	

pt	A. manípulo	J. bloqueador das rodas giratórias	T. ponto de fixação 3
	B. chassis	K. roda giratória	U. botão de libertação da roda grande
	C. botão de desenganche da asa de transporte	L. ponto de fixação 1	V. capota
	D. roda grande	M. pulseira de segurança	W. botão quadrado branco
	E. cesto	N. cobre-pés da alcofa	X. bloqueio de desdobramento
	F. asa de transporte	O. peças de fixação de regulação do manípulo	Y. suspensão
	G. cadeira	P. ponto de fixação 2	
	H. cinto de segurança	Q. reforço da alcofa	
	I. botão para remoção das rodas giratórias	R. alcofa	
		S. travão	

ru	A. ручка	J. замок поворотного колеса	U. кнопка разблокирования
	B. шасси	K. поворотное колесо	большого колеса
	C. кнопка разблокирования ручки	L. точка крепления 1	V. капюшон
	для переноски	M. ремешок на запястье	W. квадратная белая ручка
	D. большое колесо	N. люлька	X. блокировка раскладывания
	E. сумка под сиденьем	O. регулирующий зажим ручки	Y. подвеска
	F. ручка для переноски	P. точка крепления 2	
	G. сиденье	Q. укрепляющие элементы люльки	
	H. ремни безопасности	R. фартук	
	I. кнопка разблокирования	S. тормоз	
	поворотного колеса	T. точка крепления 3	

sl	A. krmilo	L. pritrdilna točka 1	W. štirioglat bel gumb
	B. podvozje	M. zapestni trak	X. zložljivi zaklep
	C. gumb za sprostitev ročaja	N. košara za otroka	Y. vzmeterje
	D. veliko kolo	O. objemke za prilagoditev krmila	
	E. torba pod sedežem	P. pritrdilna točka 2	
	F. ročaj	Q. ojačevalnik za košaro za otroka	
	G. sedež	R. pregrinjalo košare za otroka	
	H. jermen	S. zavora	
	I. gumb za sprostitev vrtljivih koles	T. pritrdilna točka 3	
	J. zaklep vrtljivih koles	U. gumb za sprostitev velikih koles	
	K. vrtljivo kolo	V. strešica	

sv	A. styre	L. fästpunkt 1	W. fyrkantig vit knapp
	B. chassi	M. handledsband	X. fälla upp lås
	C. bärhandtagets frigöringsknapp	N. liggdel	Y. fjädring
	D. stora hjul	O. justeringsklämmor till styret	
	E. varukorg	P. fästpunkt 2	
	F. bärhandtag	Q. inlägg för liggdel	
	G. sittdel	R. liggdelslock	
	H. sele	S. broms	
	I. frigöringsknapp till swivelhjul	T. fästpunkt 3	
	J. swivelås	U. frigöringsknapp för stora hjul	
	K. swivelhjul	V. sufflett	

tr	A. tutma kol	J. döner kilit	U. geniş tekerleği serbest bırakma
	B. şasi	K. döner tekerlek	düşmesi
	C. taşıma kolu serbest bırakma	L. bağlantı noktası 1	V. güneş gölgesi
	düşmesi	M. bilek kayışı	W. kare beyaz buton
	D. geniş tekerlek	N. beşik	X. açılır kilit
	E. koltuk altı çantası	O. tutma kolu ayarlama klipsleri	Y. süspansiyon
	F. taşıma kolu	P. bağlantı noktası 2	
	G. koltuk	Q. beşik destek parçası	
	H. koşum takımı	R. önlük	
	I. döner tekerlek serbest bırakma	S. fren	
	düşmesi	T. bağlantı noktası 3	

ja|

- | | | |
|---------------------|-----------------|------------|
| A. ハンドルバー | K. 旋回式ホイール | V. サンキャノピー |
| B. 本体 | L. 接続点 1 | W. 白角ボタン |
| C. キャリーハンドルレバー解除ボタン | M. リストストラップ | X. 展開ロック |
| D. ラージホイール | N. バシネット | Y. サスペンション |
| E. アンダーシートバッグ | O. ハンドルバー調整クリップ | |
| F. キャリーハンドル | P. 接続点 2 | |
| G. シート | Q. キャリーコット補強具 | |
| H. 安全ベルト | R. バシネットエプロン | |
| I. 旋回式ホイール解除ボタン | S. ストッパー | |
| J. 旋回ロック | T. 接続点 3 | |
| | U. ラージホイール解除ボタン | |

ko|

- | | | |
|-----------------|----------------|-------------|
| A. 핸들바 | L. 부착 지점 1 | W. 흰색 사각 버튼 |
| B. 새시 | M. 손목 스트랩 | X. 잠금/해제 장치 |
| C. 휴대용 핸들 해제 버튼 | N. 배시넷 | Y. 서스펜션 |
| D. 대형 바퀴 | O. 핸들바 조절 클립 | |
| E. 언더시트 백 | P. 부착 지점 2 | |
| F. 휴대용 핸들 | Q. 배시넷 스틱프너 | |
| G. 시트 | R. 배시넷 커버 | |
| H. 안전 벨트 | S. 브레이크 | |
| I. 회전 바퀴 해제 버튼 | T. 부착 지점 3 | |
| J. 회전 바퀴 잠금 장치 | U. 대형 바퀴 해제 버튼 | |
| K. 회전 바퀴 | V. 섀 캐노피 | |

zh|

- | | | |
|------------|------------|-----------|
| A. 手把管 | L. 连接点 1 | W. 白色方形按钮 |
| B. 车架 | M. 手把织带 | X. 展开锁 |
| C. 前扶手释放按钮 | N. 提篮 | Y. 悬架 |
| D. 大轮胎 | O. 手把管调节扣 | |
| E. 购物袋 | P. 连接点 2 | |
| F. 前扶手 | Q. 提篮布加强杆 | |
| G. 座椅 | R. 脚罩 | |
| H. 安全带 | S. 刹车 | |
| I. 转向轮释放按钮 | T. 连接点 3 | |
| J. 转向锁 | U. 大轮胎释放按钮 | |
| K. 转向轮 | V. 遮阳篷 | |

W. כפתורים לבנים מרובעים
X. נעילה לפתיחת הקיפול
Y. מתלה

L. נקודת החיבור 1
M. רצועת פרק כף היד
N. עריסת שכובה
O. תפסים לכוונון ידית האחזיה
P. נקודת החיבור 2
Q. מייצב עריסת שכובה
R. כיסוי חורף עריסת שכובה
S. בלם
T. נקודת החיבור 3
U. כפתור שחרור גלגל גדול
V. גגון שמש

A. ידית דחפיה
B. שלדה
C. כפתור שחרור ידית נשיאה
D. גלגל גדול
E. תיק ממתח למושב
F. ידית אחזיה
G. מושב
H. ריתמה
I. כפתור שחרור גלגלים
J. מנעול גלגל הסביבול
K. גלגל סביבול

he

instructions - visual language



visual check OK
afbeelding controle OK
vizuální kontrola OK
visuel kontrol OK
optische kontrolle OK
comprobación visual correcta
οπτικός έλεγχος OK
silmävarainen tarkistus OK

contrôle visuel OK
esito positivo del controllo visivo
visuell kontroll OK
kontrola wzrokowa OK
verificação visual OK
наружный осмотр не выявил неисправностей

znak 'pravilno'
visuell kontrolli OK
görsel kontrol tamam
目視点検 OK
육안 확인 정상
正確的效果
בדיקה חזותית - עבר



visual check wrong
afbeelding controle niet goed
vizuální kontrola - špatně
visuel kontrol ikke korrekt
optische kontrolle falsch
comprobación visual incorrecta
οπτικός έλεγχος λάθος
silmävarainen tarkastus ei

hyväksyttävä
contrôle visuel erreur
esito negativo del controllo visivo
visuell kontroll feil
kontrola wzrokowa negatywna
verificação visual errada
наружный осмотр выявил

неисправность
znak 'napačno'
visuell kontrolli fel
görsel kontrol yanlış
目視点検間違え
육안 확인이 틀림
錯誤的效果
בדיקה חזותית נכשלה



audible click
hoorbare klik
slyšitelné cvaknutí
tydelig kliklyd
hörbares klickgeräusch
clíc sonoro
ηχητικό κλικ

kuulet naksahduksen
clíc audible
scatto (clíc)
hørbart klikk
slychać kliknięcie
clique audible
слышимый щелчок

zvočni klik
hörbart klickande ljud
duyulabilir klik sesi
聞き取れるクリック音
찰각 소리가 들림
“咔嚓”声
נקישה נשמעת



Perform action on both sides of the product.
Actie verrichten aan beide zijden van het product.
Opatření provedte na obou stranách výrobku.
Gør som anvist på begge sider af produktet.
Fassen Sie an beiden Seiten des Produkts an.
Εκτελέστε την ενέργεια και στις δύο πλευρές του προϊόντος.
Realiza la acción en ambos lados del producto.

Tee toimet tuotteen molemmilla puolilla.
Répétez l'action des deux côtés du produit.
Esegui l'operazione su entrambi i lati del prodotto.
Følg instruksjonene på begge sider av produktet.
Powtórz czynność z obu stron wózka.
Execute a ação em ambos os lados do produto.
Выполните это действие с обеих сторон коляски.

Ukrepajte na obeh straneh izdelka.
Utför åtgärden på båda sidor om produkten.
İşlemi, ürünün iki yanına da uygulayın.
ベビーカーの両サイドから操作してください。
제품의 양쪽에서 작업을 수행해야 합니다.
对产品的两侧均执行操作。
נקוט פעולה משני צידי המוצר.



video available
video beschikbaar
k dispozici je video
video tilgængelig
Video verfügbar
διατίθεται video
vídeo disponible
video saatavissa

vidéo disponible
video disponibile
video tilgjengelig
video dostępne
vídeo disponível
видео
video na voljo
video tillgänglig

video mevcut
ビデオをご覧ください
비디오 도움을 받을 수 있습니다
提供视频

וימו ואדיו



When you see this symbol in the instructional part of the user guide, please refer to the warnings chapter for ensuring the safe use of the Bugaboo Fox².

Wanneer je op de instructiepagina's in de gebruiksaanwijzing dit symbool ziet, raadpleeg dan het hoofdstuk met waarschuwingen om er zeker van te zijn dat je de Bugaboo Fox² veilig gebruikt.

Pokud uvidíte v instruktážní části uživatelské příručky tento symbol, podívejte se do kapitoly varování, abyste si ověřili bezpečné používání kočárku Bugaboo Fox².

Når du ser dette symbol i instruktionsdelen af brugervejledningen, skal du bladre om til afsnittet om advarsler for at sikre, at du anvender Bugaboo Fox² korrekt.

Wenn Sie dieses Symbol in der Bedienungsanleitung sehen, lesen Sie bitte den Abschnitt mit den Warnhinweisen, um die sichere Nutzung des Bugaboo Fox² sicherzustellen.

Όταν βλέπετε αυτό το σύμβολο στο τμήμα οδηγιών των οδηγιών χρήσης, παρακαλούμε ανατρέξτε στο κεφάλαιο προειδοποιήσεων για τη διασφάλιση της ασφαλούς χρήσης του Bugaboo Fox².

Cuando veas este símbolo en las instrucciones de la guía del usuario, consulta el capítulo de advertencias para garantizar un uso seguro del Bugaboo Fox².

Tämä symboli ilmaisee käyttöoppaan ohjeosassa vaaraa. Katso lisätietoja varoituksia sisältävästä luvusta ja varmista, että käytät Bugaboo Fox² turvallisesti.

Lorsque vous apercevez ce symbole dans les instructions du mode d'emploi, veuillez vous référer au chapitre sur les avertissements pour garantir une utilisation en toute sécurité de la Bugaboo Fox².

Quando vedi questo simbolo nelle istruzioni della guida all'uso, fai riferimento al capitolo relativo alle avvertenze per informazioni su come usare Bugaboo Fox² in modo sicuro.

Når du ser dette symbolet i instruksjonsdelen av bruksanvisningen, kan du se kapittelet om advarsler for å sikre at du bruker Bugaboo Fox² på en trygg måte.

Jeśli widzisz ten symbol w instruktażowej części przewodnika, przejdź do rozdziału z ostrzeżeniami. Dzięki temu zyskasz pewność, że korzystasz z wózka Bugaboo Fox² w bezpieczny sposób.

Quando vir este símbolo nas instruções do guia do utilizador, consulte o capítulo de avisos para garantir que utiliza o Bugaboo Fox² de uma forma segura.

Когда вы увидите этот символ в инструкционной части руководства пользователя, см. главу с предупреждениями, чтобы обеспечить безопасное использование коляски Bugaboo Fox².

Če v navodilih v priročniku za uporabnike vidite ta znak, preberite poglavje z opozorili, kjer so navodila za varno uporabo vozička Bugaboo Fox².

Om du ser den här symbolen i anvisningarna i användarhandboken ska du titta i varningskapitlet så att du använder Bugaboo Fox² säkert.

Kullanıcı kılavuzunun açıklamalar kısmında bu simgeyi gördüğünüzde, Bugaboo Fox²'in güvenli kullanımını sağlamak için, lütfen uyarılar bölümüne başvurun.

このシンボルがユーザーガイドの使用手順に表示されている場合は、バガブー カメラオン5を安全にご使用いただくための警告ページを参照してください。

사용설명서의 지침 부분에서 이 기호를 만나면, Bugaboo Fox²의 안전한 사용 섹션의 경고 사항을 참조하십시오.

当您在本书说明书的指导说明部分看到这一符号时，请参阅警告章节，确保您将安全使用 Bugaboo Fox²。

כאשר אתה רואה את הסמל הזה בחלק ההוראות שבמדריך למשתמש, עיין ב-Bugaboo Fox²-בפרק האזהרות כדי לוודא שימוש בטוח ב-

white parts

All the white parts of your Bugaboo Fox² are functional. They're the parts that allow you to adapt and change your Bugaboo Fox².

Alle witte onderdelen van uw Bugaboo Fox² hebben een functie. Dit zijn de onderdelen waarmee u uw Bugaboo Fox² kunt verstellen en veranderen.

Všechny bílé části vašeho Bugaboo Fox² jsou funkční. Jsou to části, které vám umožňují přizpůsobit a změnit váš Bugaboo Fox².

Alle de hvide dele på din Bugaboo Fox² er funktionelle. Det er disse dele, der gør det muligt for dig at tilpasse og ændre din Bugaboo Fox².

Alle weißen Teile Ihres Bugaboo Fox² haben spezielle Funktionen/sind funktionell. Das heißt: Mit diesen Teilen können Sie Ihren Bugaboo Fox² einstellen und verändern.

Όλα τα λευκά μέρη του Bugaboo Fox² είναι λειτουργικά. Είναι τα μέρη που σας επιτρέπουν να προσαρμόσετε και να αλλάξετε το Bugaboo Fox² σας.

Todas las piezas blancas de su Bugaboo Fox² son funcionales. Son las piezas que le permiten adaptar y cambiar su Bugaboo Fox².

Kaikki valkoiset osat ovat toiminnallisia Bugaboo Fox² -vaunuissa. Ne ovat osia, joiden voit sovittaa ja muunnella Bugaboo Fox² -lastenvaunuja.

Toutes les parties blanches de votre Bugaboo Fox² sont fonctionnelles. Ces parties vous permettent d'adapter et de modifier votre Bugaboo Fox² selon vos besoins.

Tutte le parti bianche del Bugaboo Fox² sono funzionali. Questi pezzi consentono di adattare e modificare il Bugaboo Fox².

Alle de hvite delene på din Bugaboo Fox² er funksjonelle. Det er deler som gjør det mulig for deg å tilpasse og endre din Bugaboo Fox².

Wszystkie białe części Bugaboo Fox² są funkcjonalne. Są to części umożliwiające adaptowanie i modyfikowanie Bugaboo Fox².

Todas as partes brancas do seu Bugaboo Fox² são funcionais. São as partes que lhe permitem adaptar e mudar o seu Bugaboo Fox².

Все функциональные детали коляски Bugaboo Fox² выделены белым цветом. Эти детали позволяют трансформировать коляску Bugaboo Fox².

Vsi beli deli vašega vozička Bugaboo Fox² so funkcionalni. To so deli, ki vam omogočajo, da prilagodite in spremenite vaš voziček Bugaboo Fox².

Alla vita delar på din Bugaboo Fox² är funktionsdelar. Dessa delar gör att du kan anpassa och ändra din Bugaboo Fox².

Bugaboo Fox² ürününüzün tüm beyaz parçaları işlevseldir. Bunlar Bugaboo Fox² ürününüzü ayarlamanızı ve değiştirmenizi sağlayan parçalardır.







Bugaboo Fox² の白い部品がすべて機能することを確認してください。白い部品を使用して Bugaboo Fox² を調整および変更します。

Bugaboo Fox²의 흰색 부품은 모두 기능이 있습니다. 이 부분은 Bugaboo Fox²를 조정하거나 변경할 때 사용됩니다.



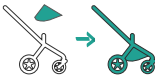



Bugaboo Fox²的所有白色部件均为功能部件。这些部件能够让你调整和变化您的 Bugaboo Fox²。

הם פונקציונליים. הם החלקים המאפשרים לך להתאים ולשנות Bugaboo Fox² כל החלקים הלבנים של להשתמש במוצר זה עד תום מאבטח נסיעה חלקה עבורך ועבור ילדך. Bugaboo Fox² את



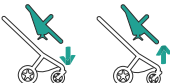





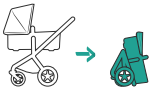
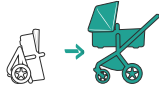
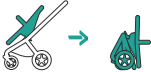

set-up

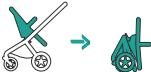
 16	 23
 18	 25
 19	 29

features

 32
 33
 34
 37
 39
 41
 42
 43

features

	44
	46
	47
	49
	50
	52
	53
	54
	55
	56
	57
	60

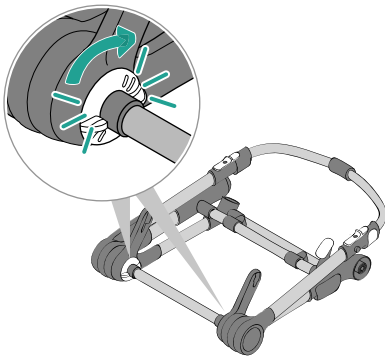
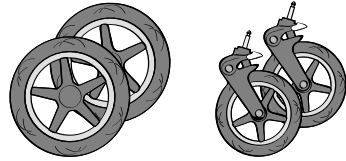
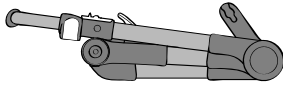
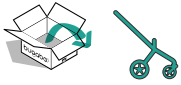

01

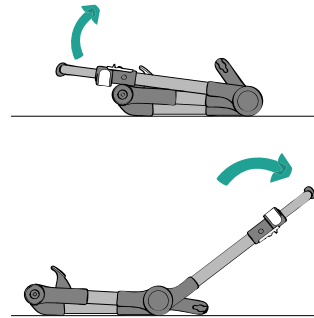

02

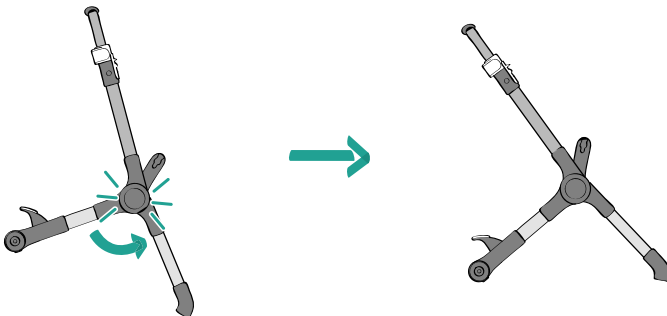

03

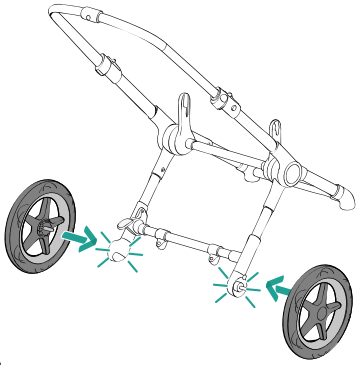

04

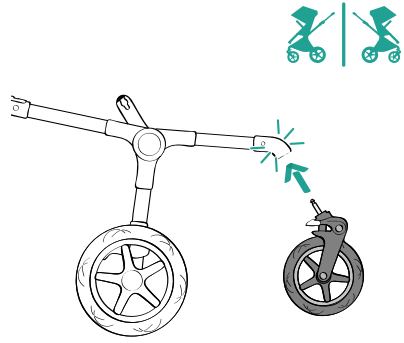

05

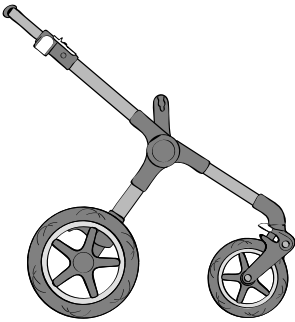

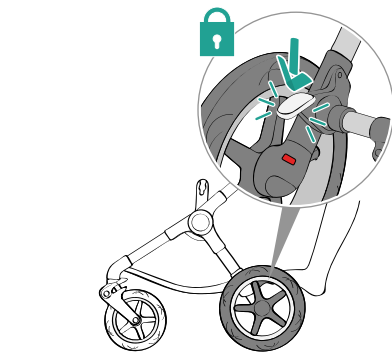
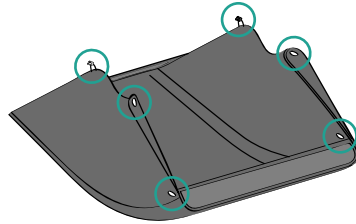
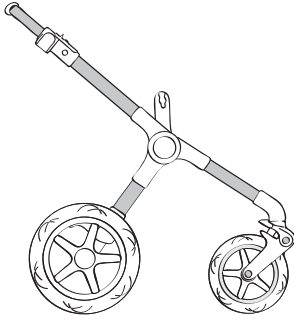
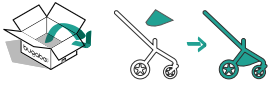

01

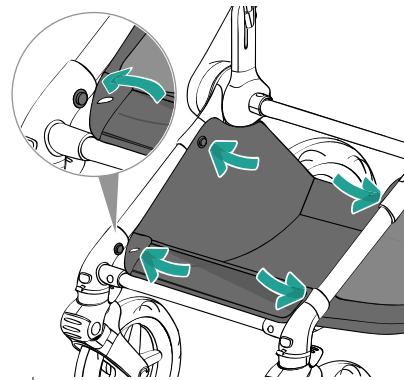

02

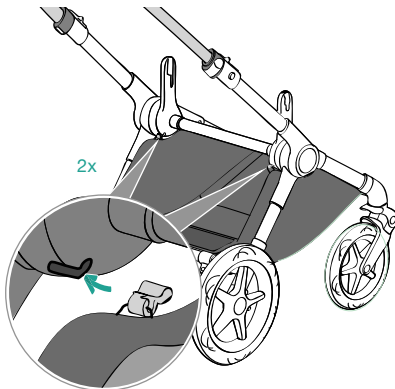

03

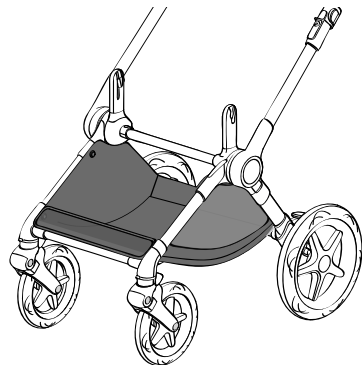

04

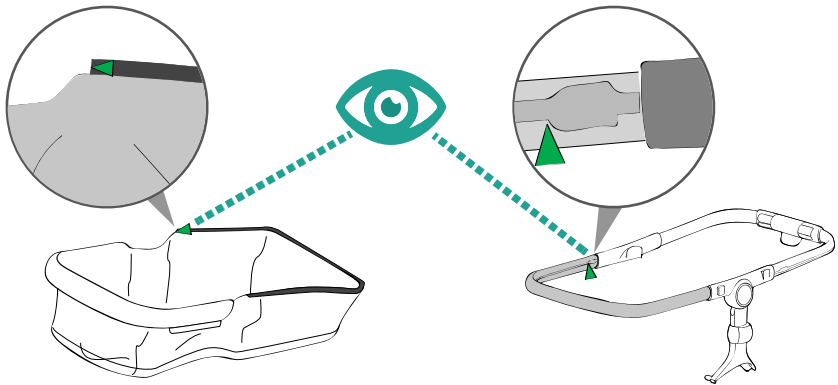
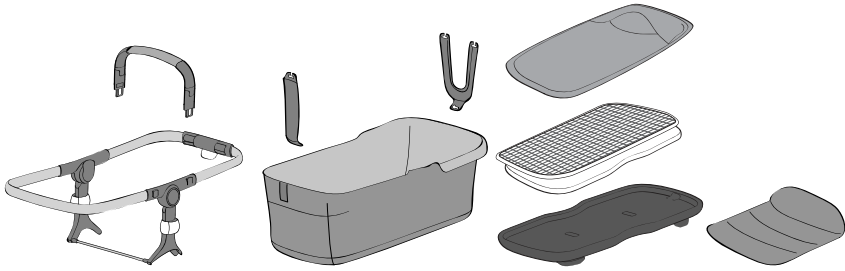

01

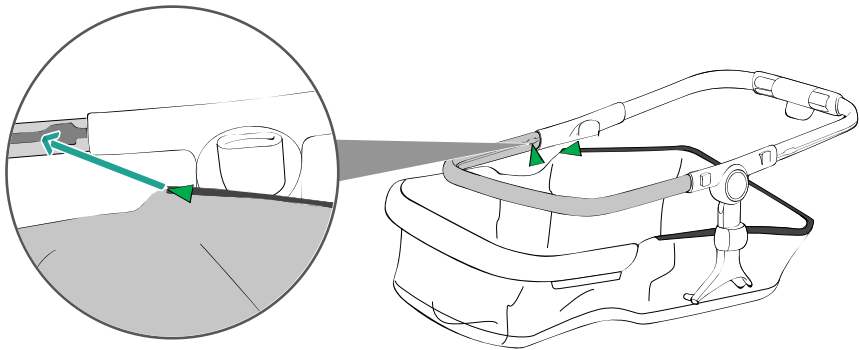

02

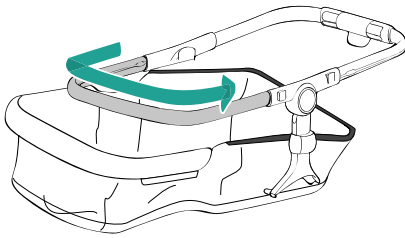

03

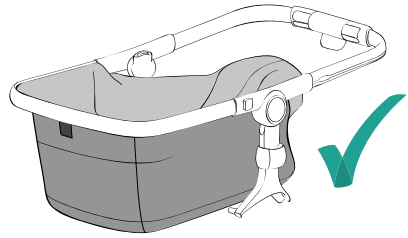

04

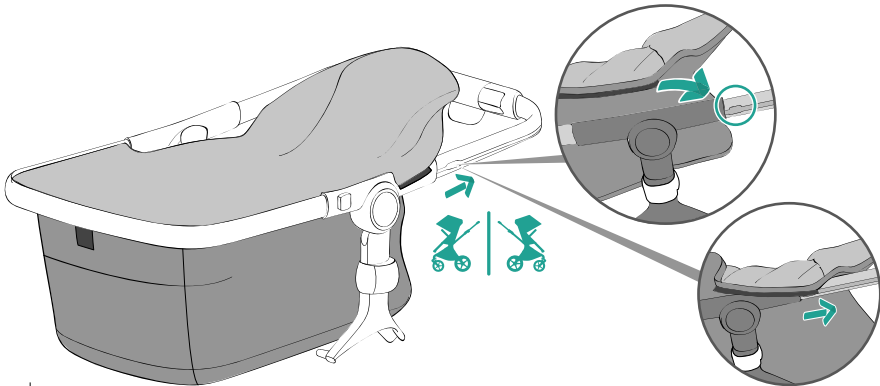

05

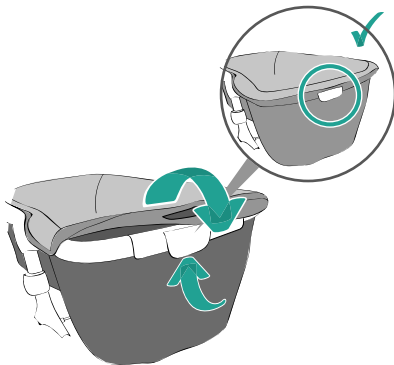

06

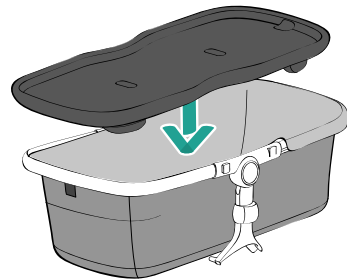

07

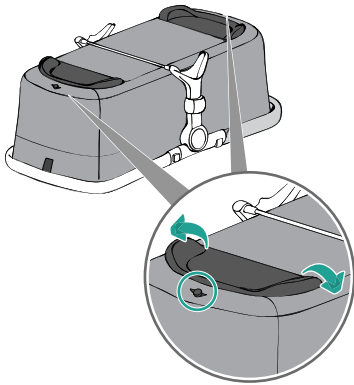

08

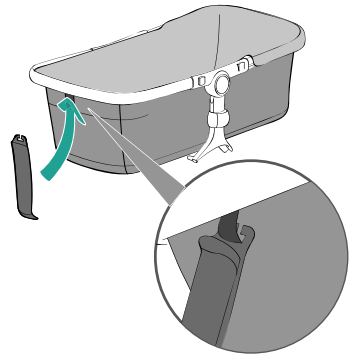

09

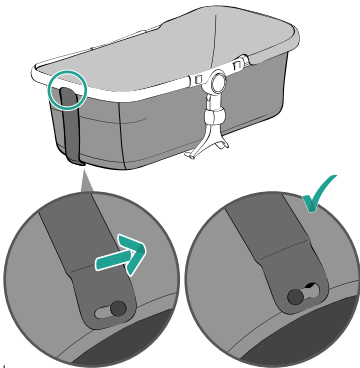

10

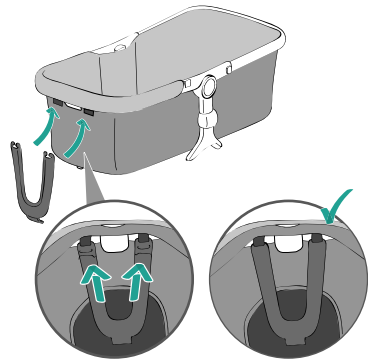

11

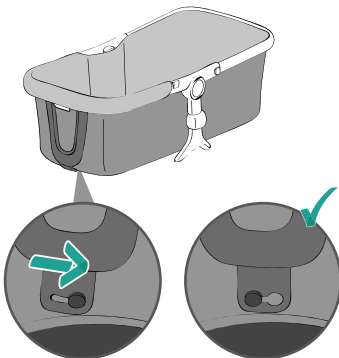

12

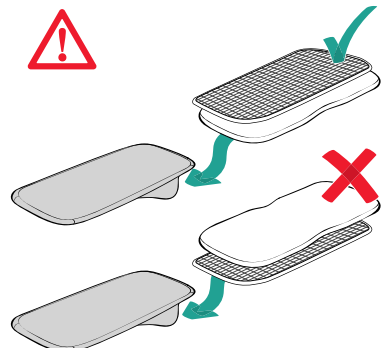

13

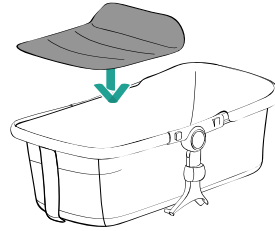
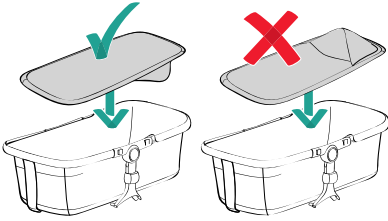

14

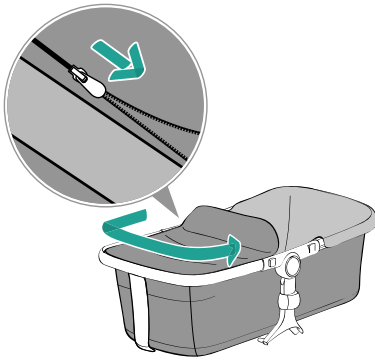

15

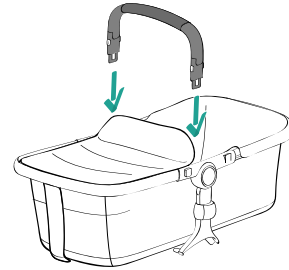

16

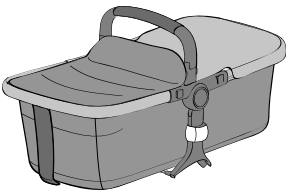

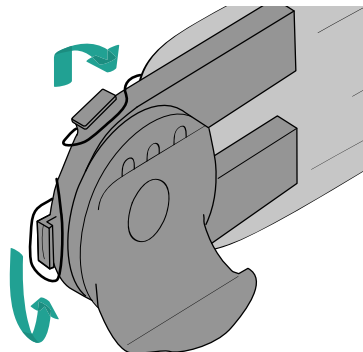
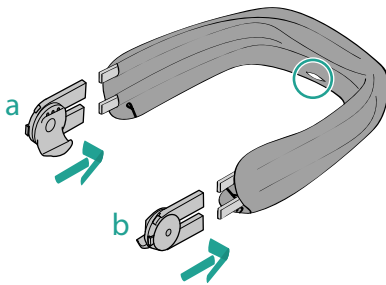
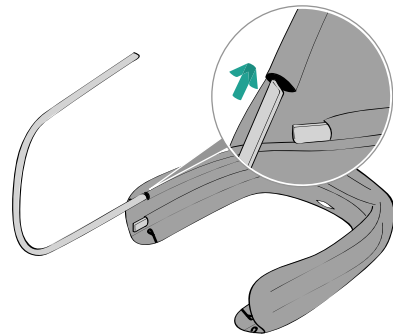
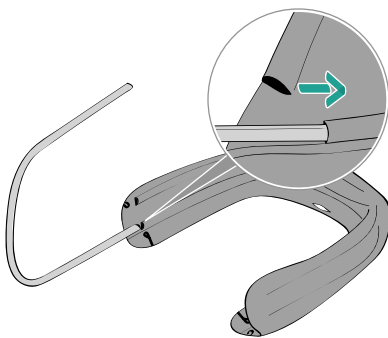
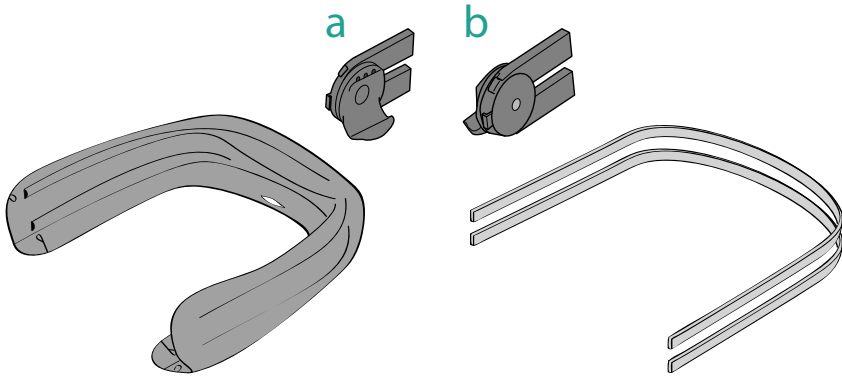
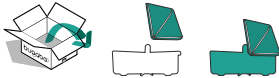

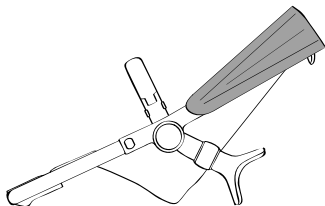
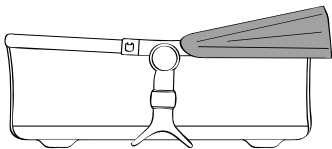
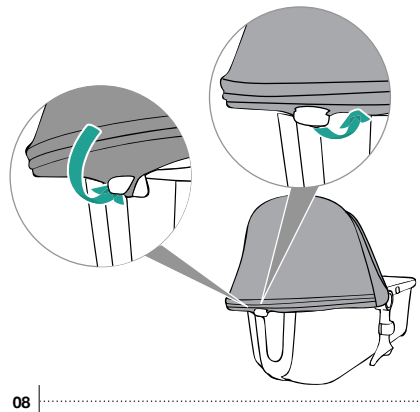
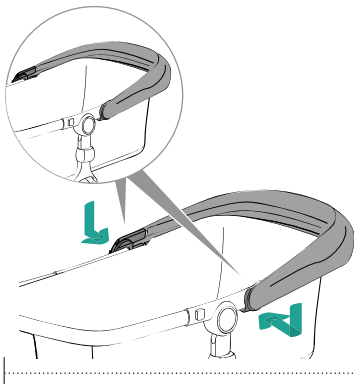
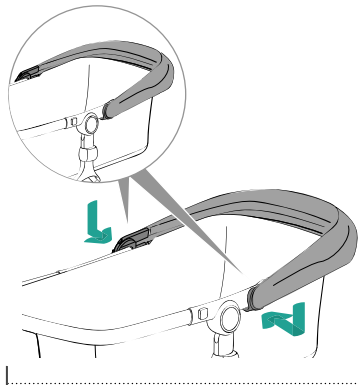
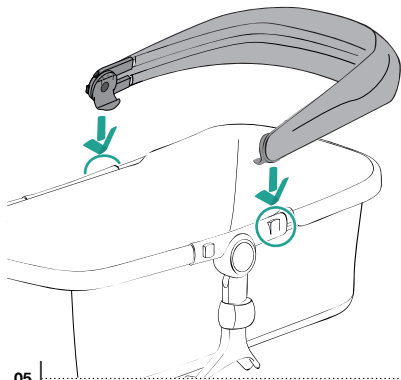

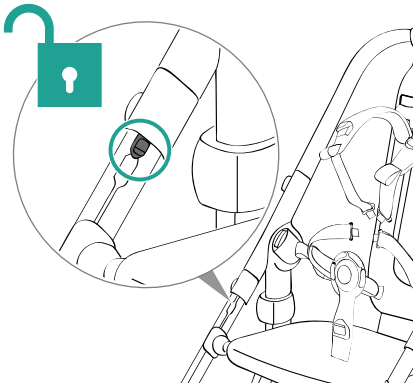
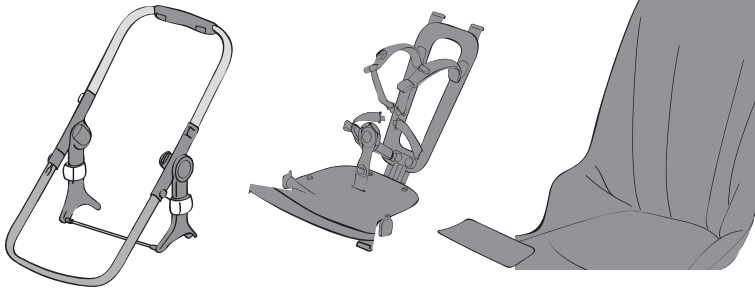

01

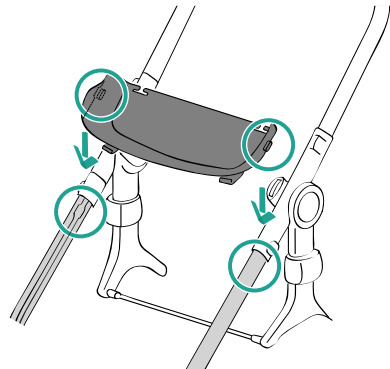

02

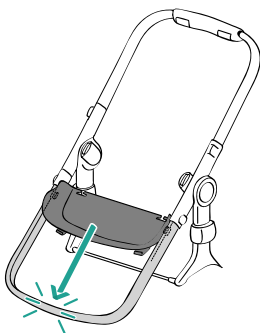

03

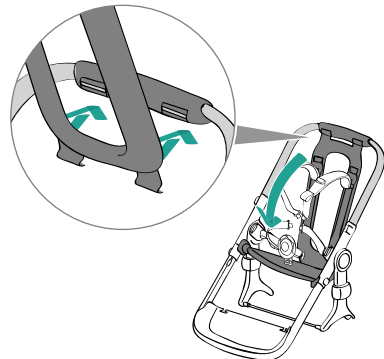

04

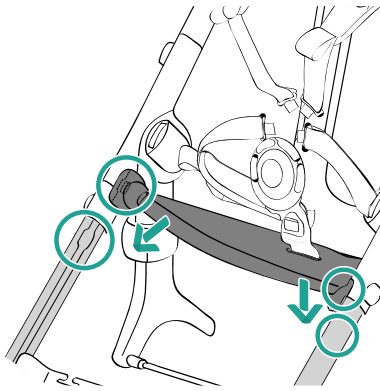

05

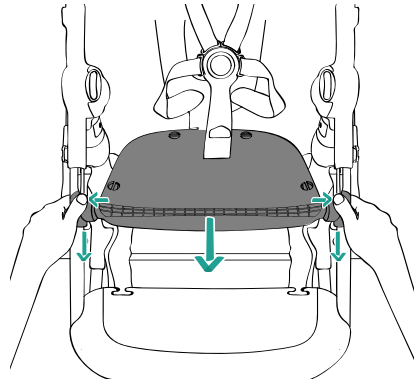

06

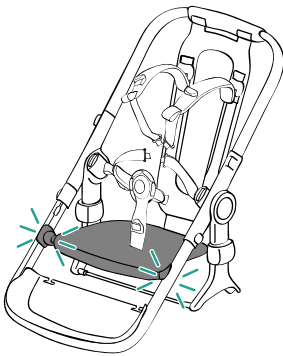

07

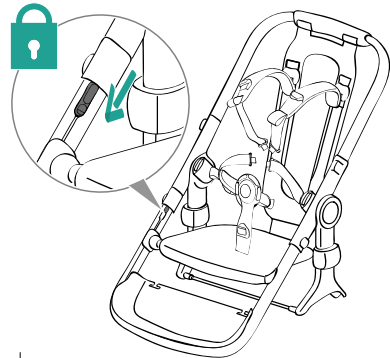

08

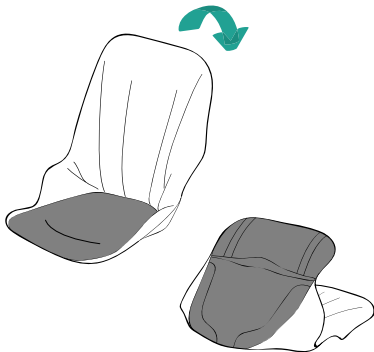

09

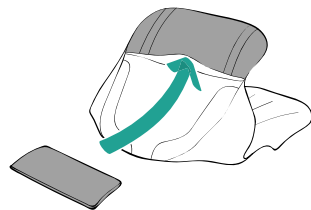

10

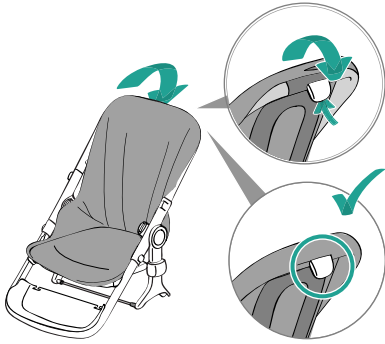

11

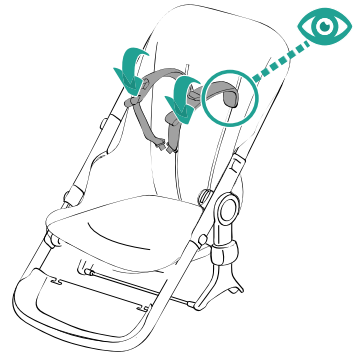

12

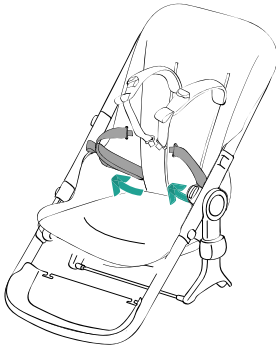

13

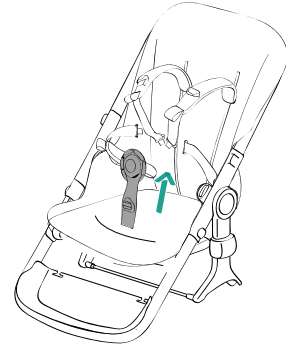

14

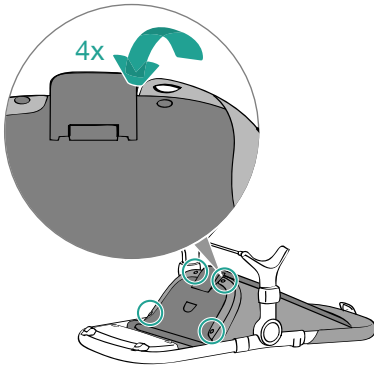

15

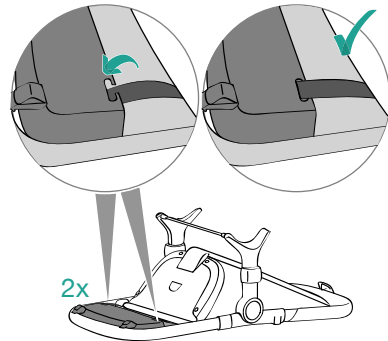

16

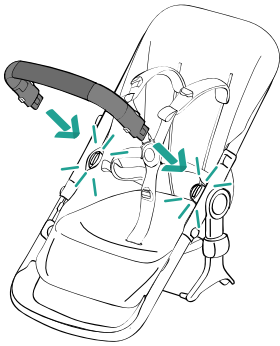

17



18

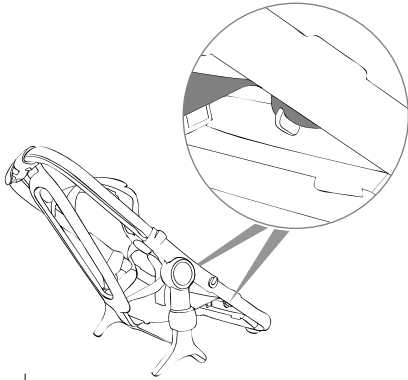

01

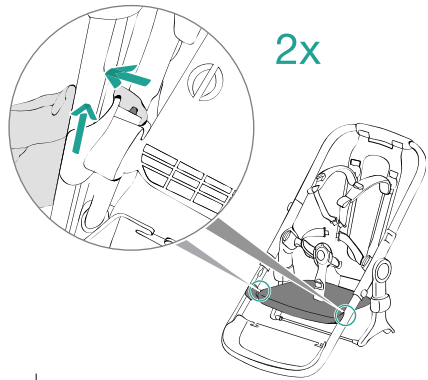

02

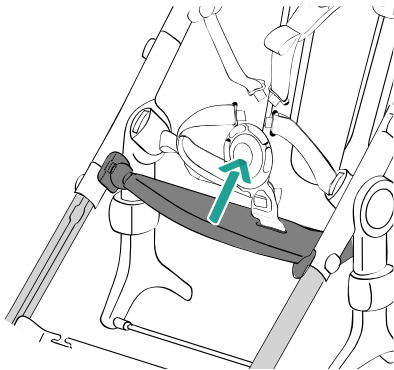

03

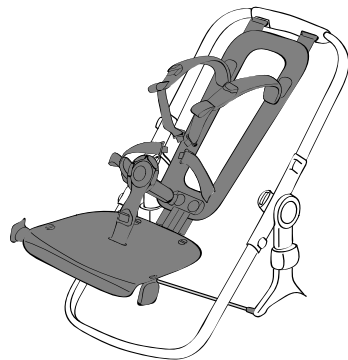

04



features |

Please pay extra attention to all the features of the Bugaboo Fox². This enables you to use this product to the fullest and secures a smooth ride for you and your child.

Wanneer je op de instructiepagina's in de gebruiksaanwijzing dit symbool ziet, raadpleeg dan het hoofdstuk met waarschuwingen om er zeker van te zijn dat je de Bugaboo Fox² veilig gebruikt.

Věnujte prosím speciální pozornost všem funkcím kočárku Bugaboo Fox². To vám umožní využívat tento výrobek naplno a zajistí plynulou jízdu vám i Vašemu dítěti.

Vær ekstra opmærksom på de mange funktioner, som Bugaboo Fox² har. På denne måde får du størst mulig glæde af produktet, og du sikrer en god oplevelse for dig selv og dit barn.

Bitte informiere dich eingehend über alle Produkteigenschaften des Bugaboo Fox². So ist sichergestellt, dass du ihn optimal benutzt, damit du mit deinem Kind ein ruhiges Fahrerlebnis genießt.

Δώστε ιδιαίτερη προσοχή σε όλα τα χαρακτηριστικά του Bugaboo Fox². Αυτό θα σας επιτρέψει να χρησιμοποιήσετε το προϊόν στο έπακρο και διασφαλίζει μια ομαλή βόλτα για εσας και το παιδί σας.

Por favor, presta especial atención a todas las características del Bugaboo Fox². Esto te permitirá sacar el máximo partido a este producto y te garantizará el paseo más suave para ti y para tu hijo.

Kiinnitä erityishuomiota kaikkiin Bugaboo Fox²in ominaisuuksiin. Niin voit hyödyntää tätä tuotetta kaikin mahdollisin tavoin ja varmistaa tasaisen ajon itsellesi ja lapsellesi.

Veillez prêter une attention particulière à toutes les caractéristiques de la Bugaboo Fox². Cela vous permettra d'utiliser ce produit au maximum de ses capacités et d'assurer une conduite agréable pour vous et votre enfant.

Si prega di prestare particolare attenzione a tutte le caratteristiche di Bugaboo Fox². Questo consente di sfruttare appieno le funzioni del prodotto oltre ad assicurare una passeggiata in sicurezza a te e al tuo bambino.

Vær ekstra oppmerksom på alle funksjonene til Bugaboo Fox². Dette lar deg bruke produktet best mulig, og du sikrer en god opplevelse både for deg og barnet ditt.

Prosimy zwrócić szczególną uwagę na wszystkie funkcje Bugaboo Fox². Umożliwi to pełne wykorzystanie produktu i zapewni płynną jazdę Tobie i Twojemu dziecku.

Por favor preste atenção redobrada a todas as características do Bugaboo Fox². Isto permite-lhe usar este produto no seu máximo potencial e assegura uma viagem suave para si e o seu filho.

Внимательно изучите все функции коляски Bugaboo Fox², чтобы по-максимуму использовать все ее возможности и получать удовольствие от прогулок с ребенком.

Pozorno si oglejte vse funkcije vozička Bugaboo Fox². Tako boste lahko izkoristili vse njegove prednosti in poskrbeli, da bo uporaba vozička prijetna tako za vas kot za otroka.

Vänligen läs noggrant igenom informationen om Bugaboo Fox² funktioner, så att du kan använda produkten på bästa sätt och att skapa trygga, smidiga åkturer för dig och ditt barn.

Lütfen Bugaboo Fox²'in tüm özelliklerine çok dikkat edin. Bu, üründen en iyi şekilde faydalanmanızı sağlar ve hem sizin hem de çocuğunuz için güvenli bir sürüşü garanti eder.

バグブー リンクスの機能に関する記述に特にご注意ください。製品を最大限に活用できると共に、あなたとお子様のためのスムーズな走行が保証されます。

Bugaboo Fox² 제품을 안전하게 사용할 수 있도록 제품의 모든 기능을 반드시 확인해 주십시오.

请特别关注 Bugaboo Fox² 的所有特性。这可让您充分使用该产品，并确保您和您的孩子享受平稳的乘车体验。

להשתמש במוצר זה במלואו ומבטיח נסיעה חלקה עבורך ועבור ילדך. הדבר מאפשר לך Bugaboo Fox² אנו שימו לב במיוחד לכל התכונות של

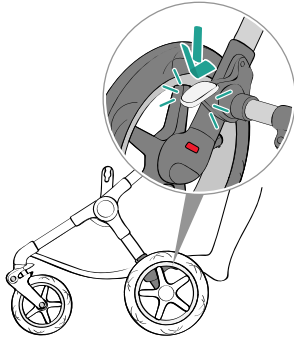

01

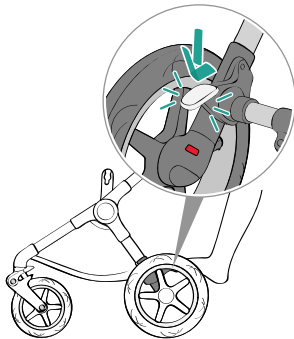
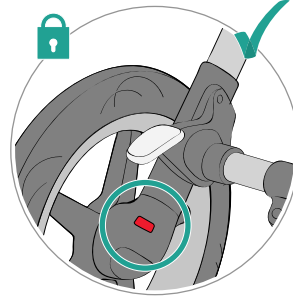

02

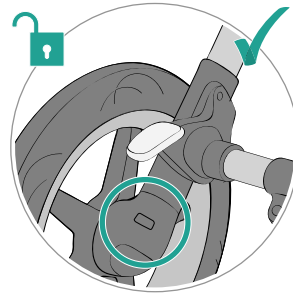

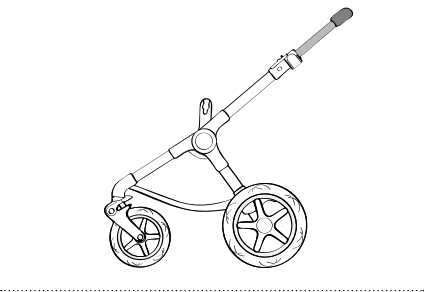
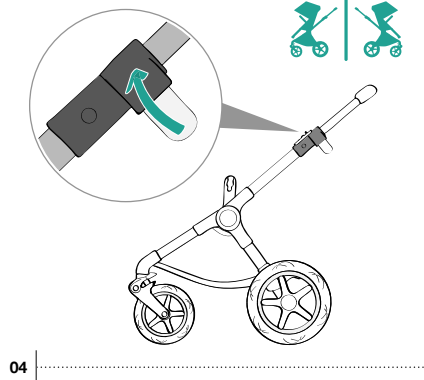
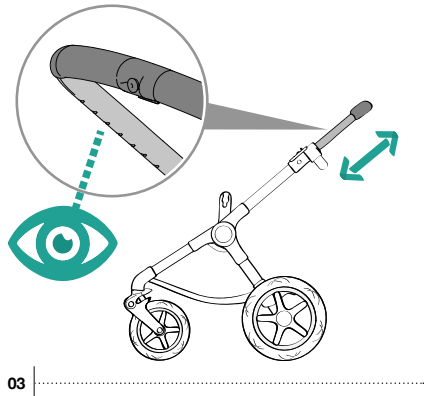
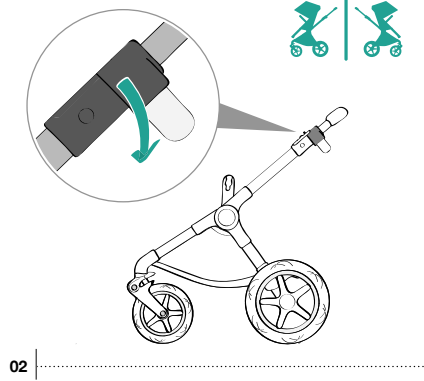
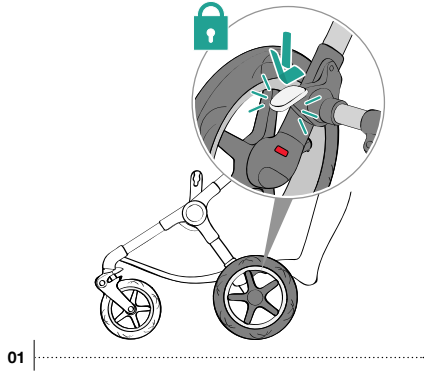

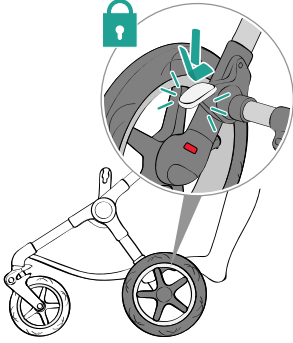

01

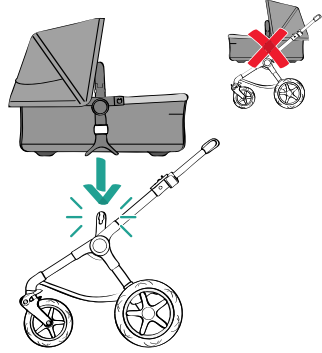

02

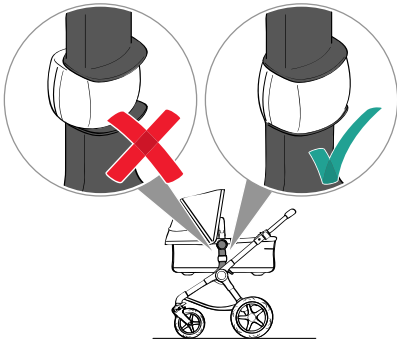

03

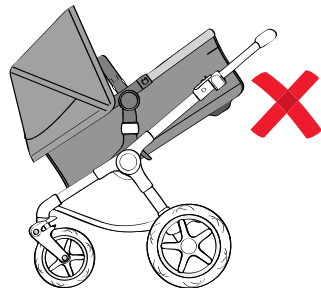
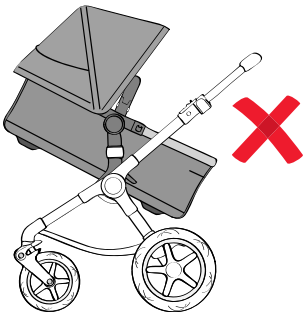
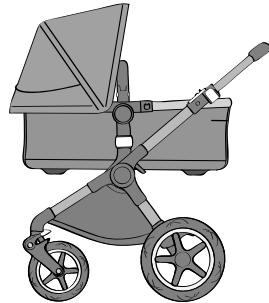

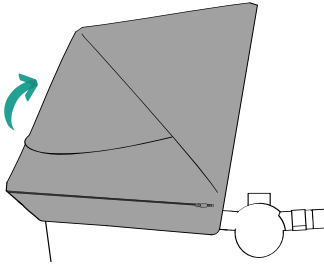

01 |

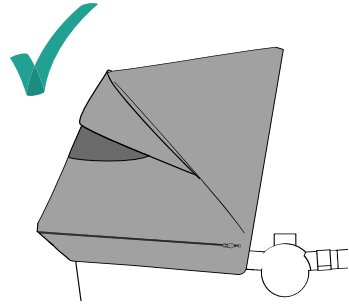

02 |

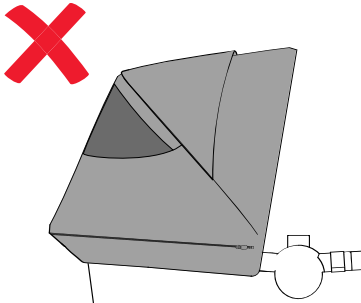

03 |

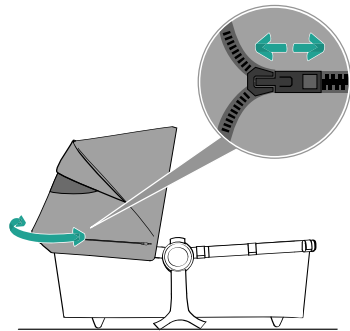

04 |

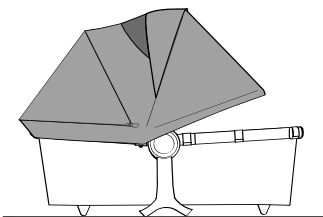

.....

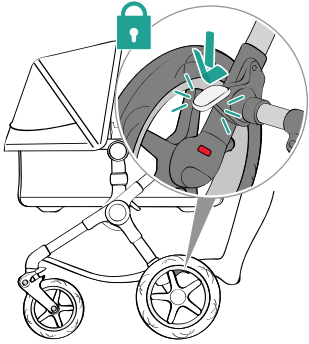

01 |

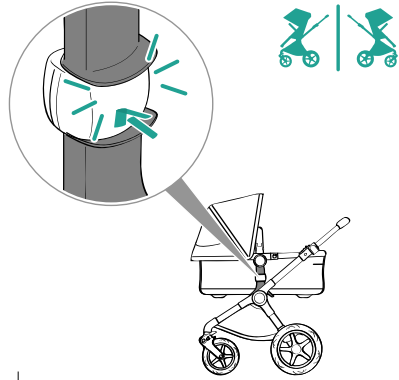

02 |

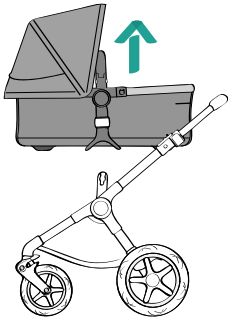

03 |

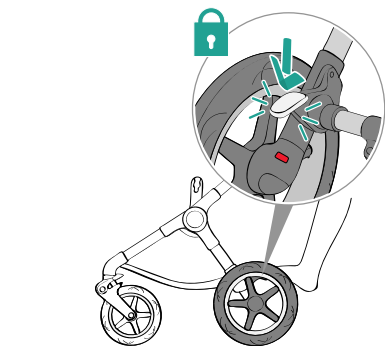

01 |

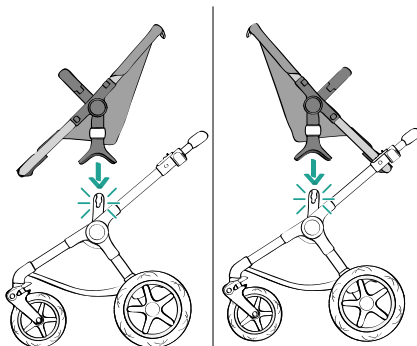

02 |

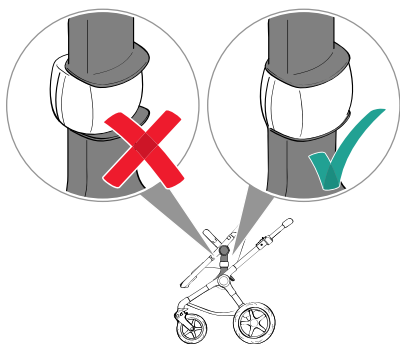

03 |

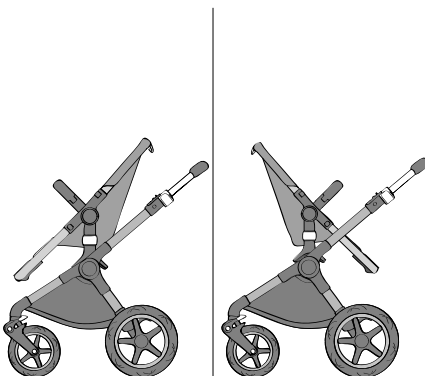

.....

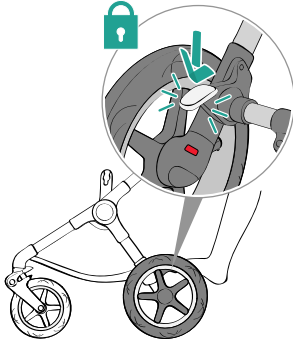

01 |

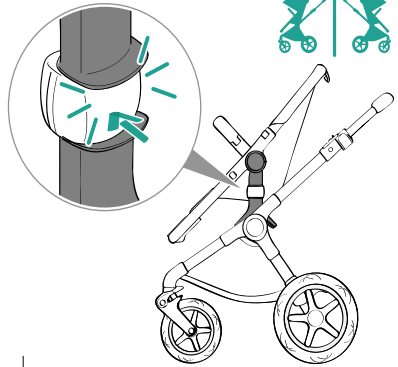

02 |

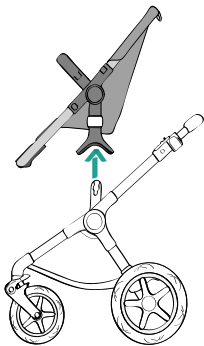

03 |

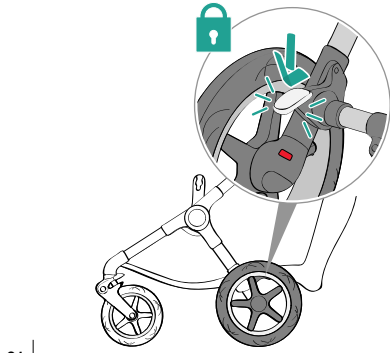

01

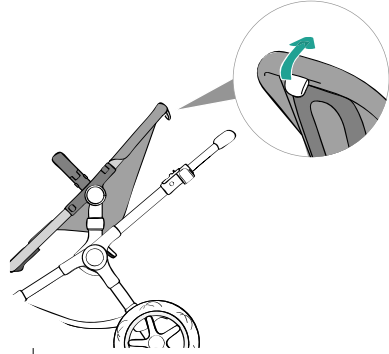

02

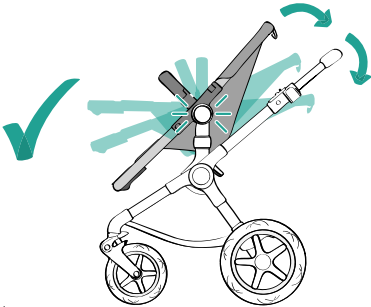

03

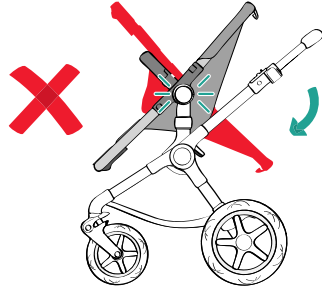

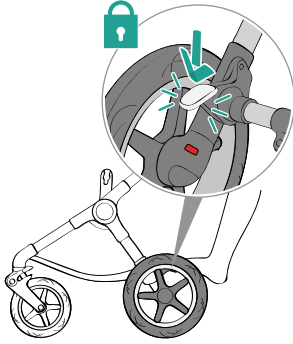

01

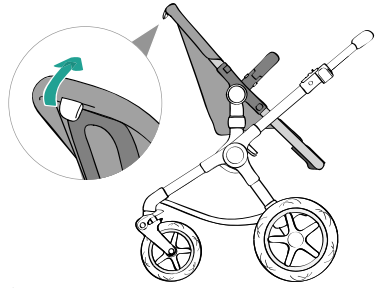

02

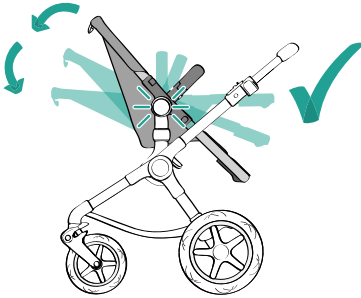

03

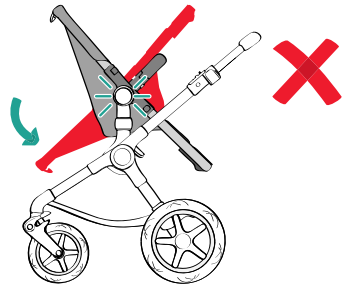

04

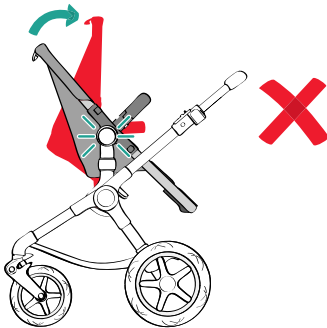

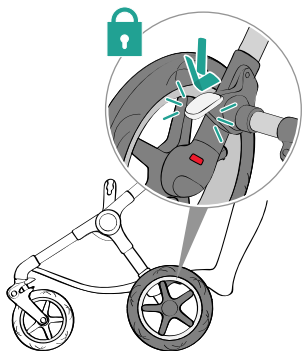

01 |

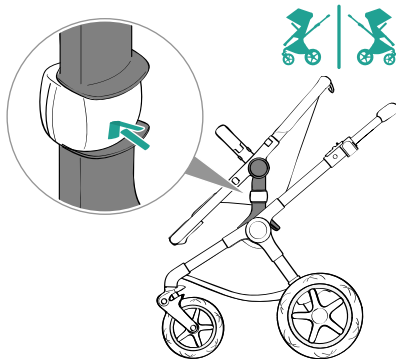

02 |

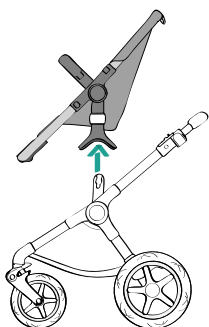

03 |

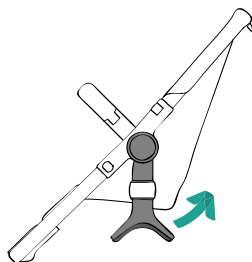

04 |

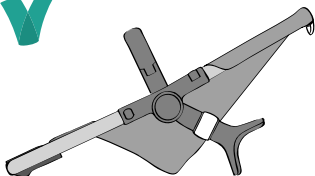

.....

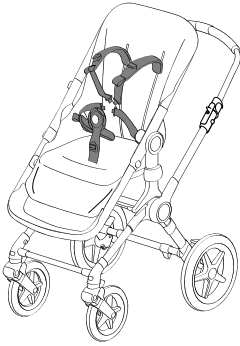

01 |

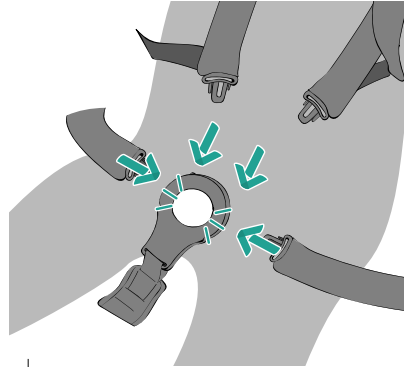

02 |

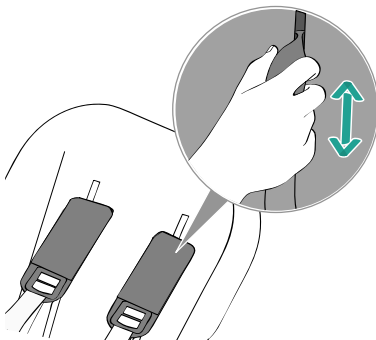

03 |

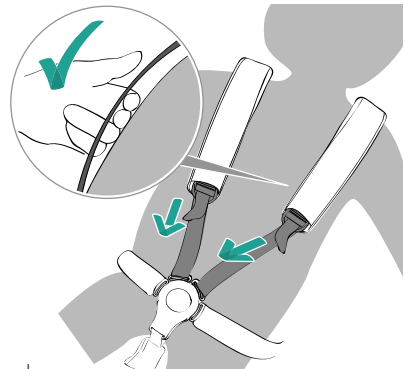

04 |

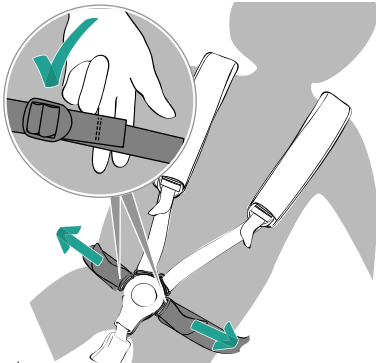

05 |

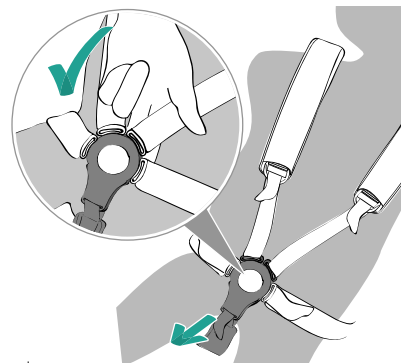

06 |

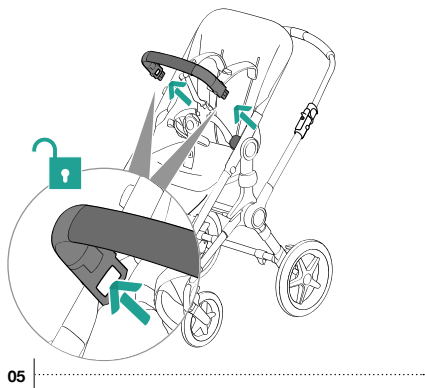
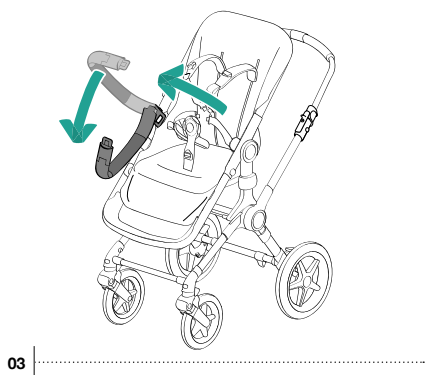
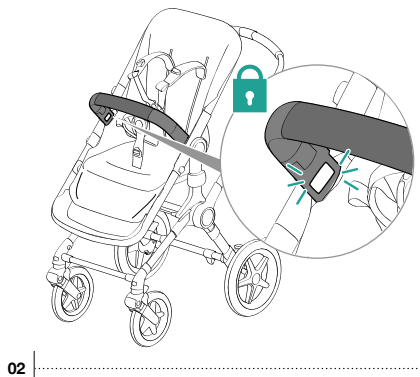
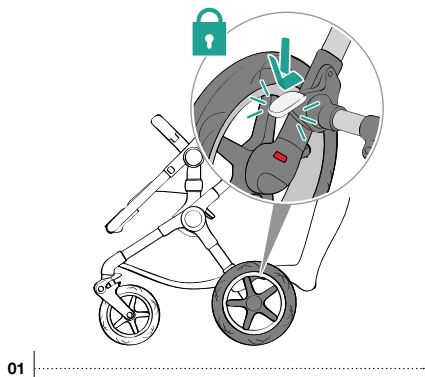

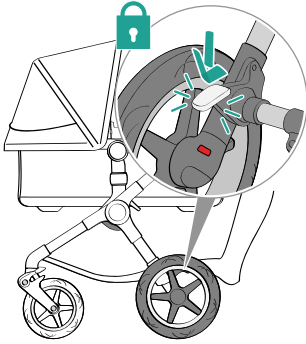
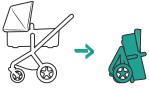

01

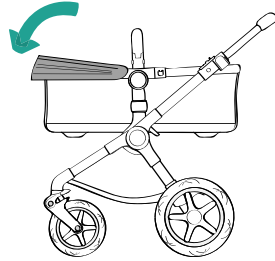

02

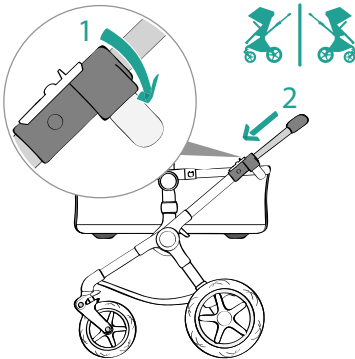

03

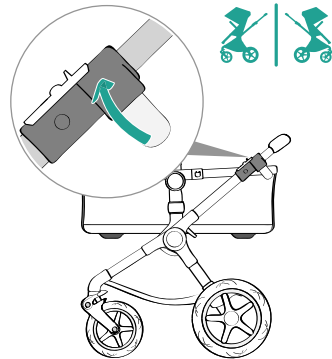

04

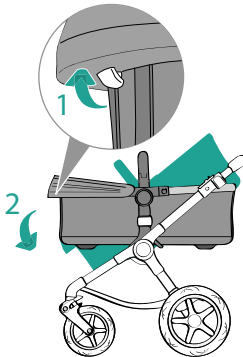

05

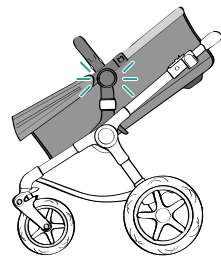

06

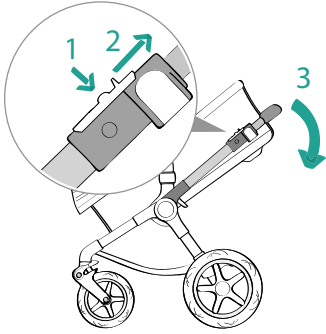

07

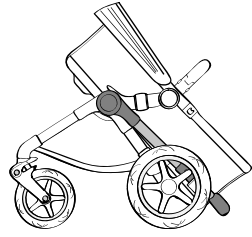

08

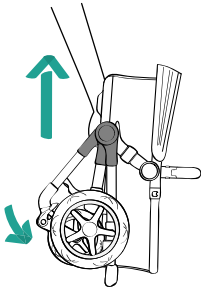

09

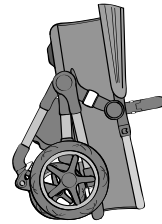

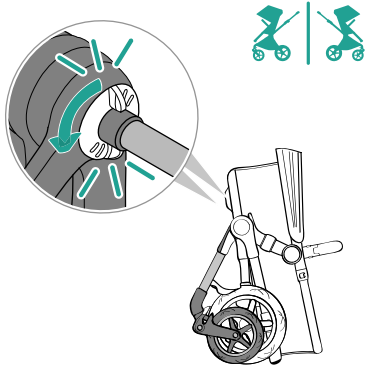
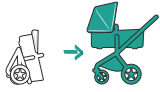

01 |

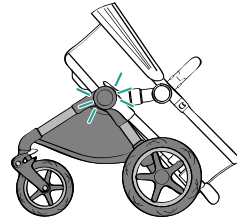

02 |

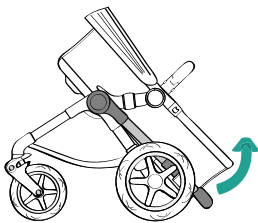

03 |

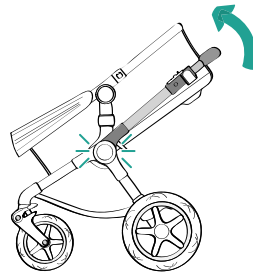

04 |

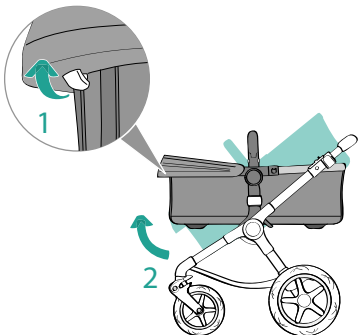

05 |

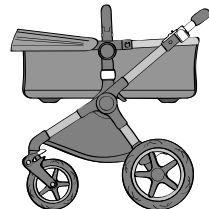

.....

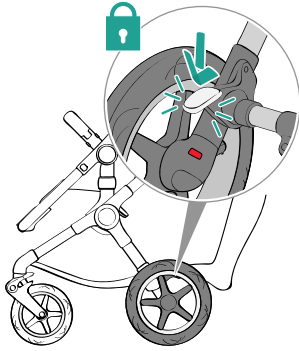

01

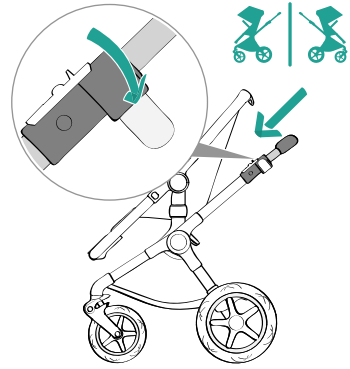

02

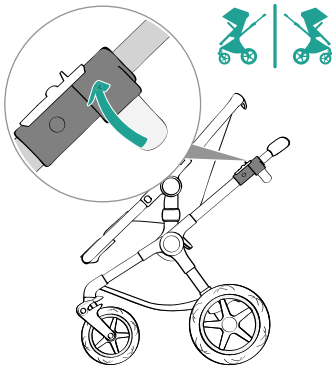

03

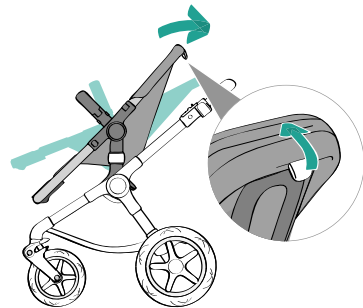

04

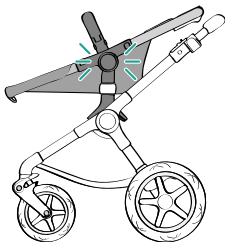

05

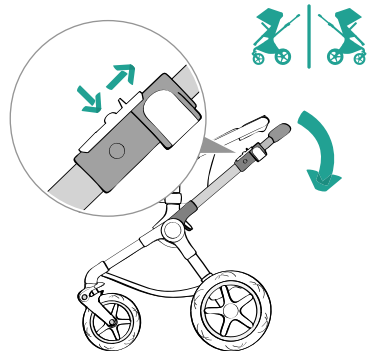

06

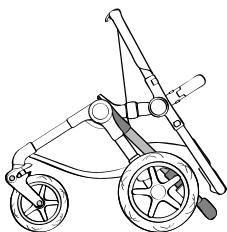

07

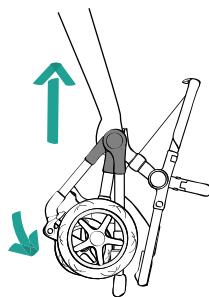

08

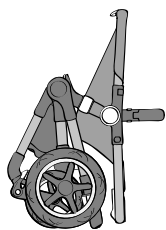

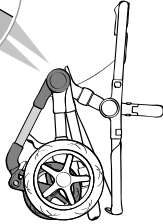
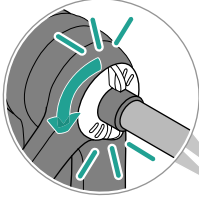

01

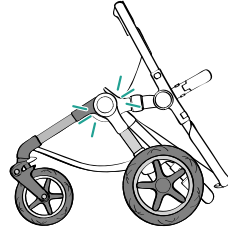

02

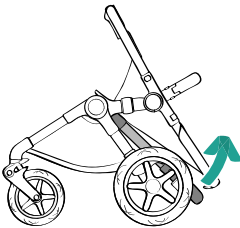

03

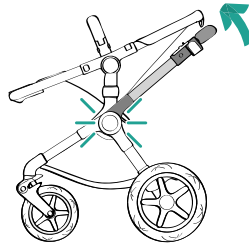

04



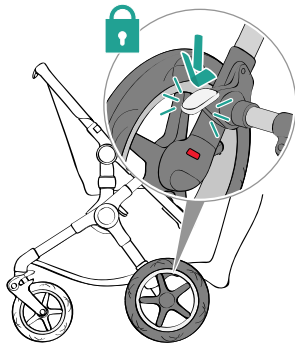

01

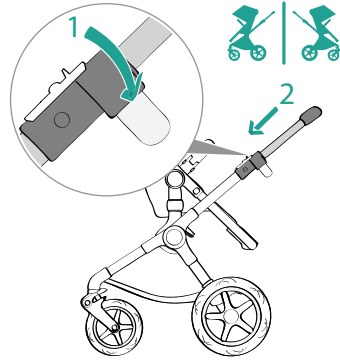

02

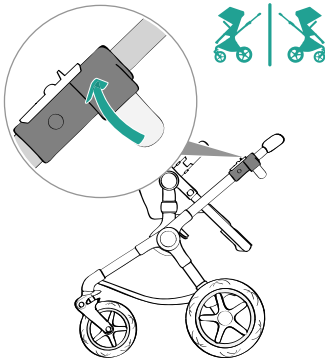

03

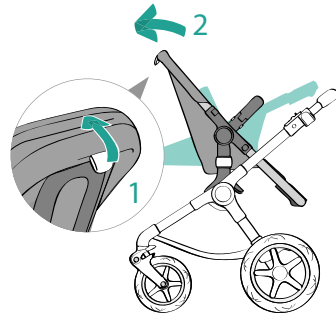

04

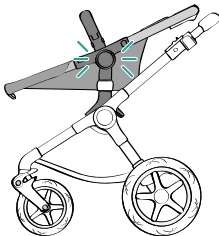

05

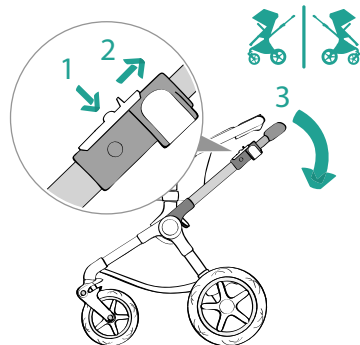

06

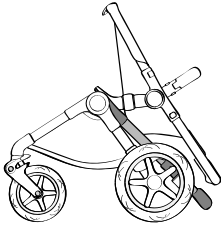

07

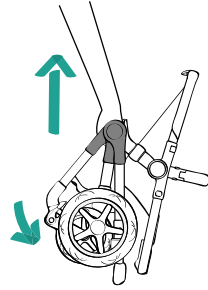

08

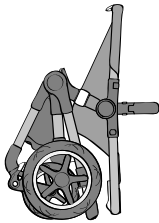

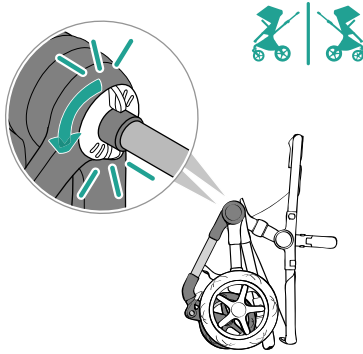

01

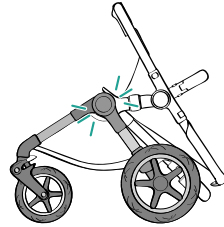

02

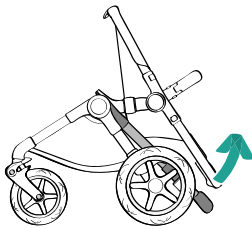

03

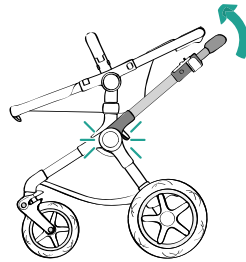

04

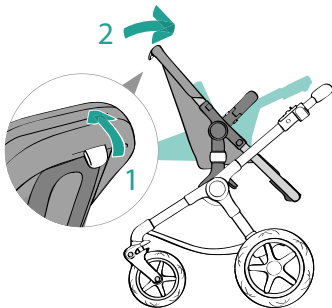

05



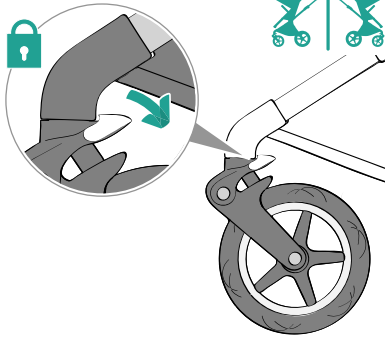

01

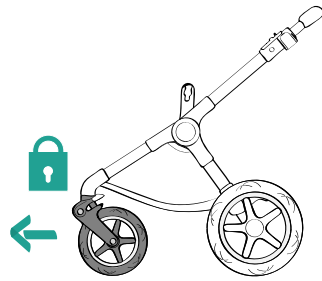

02

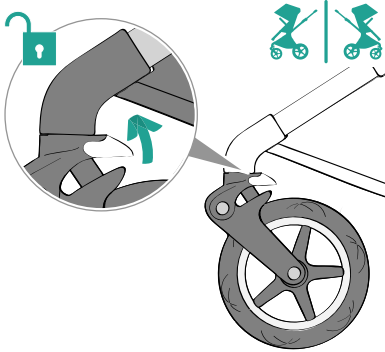

03

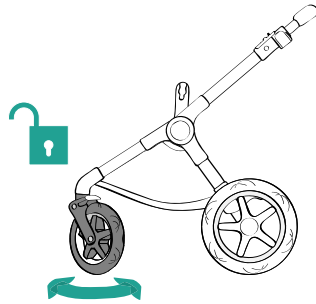

04

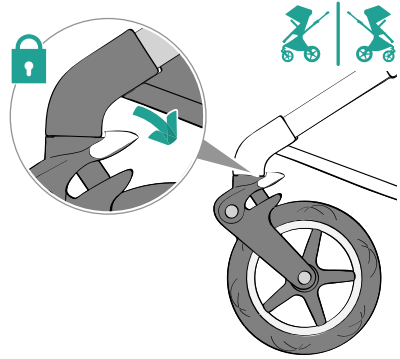
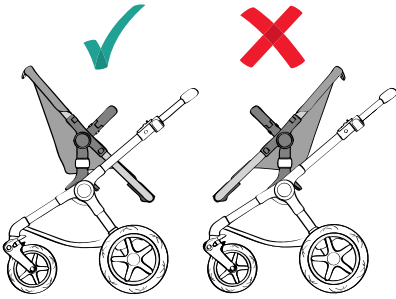

01

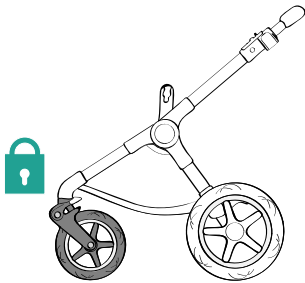

02

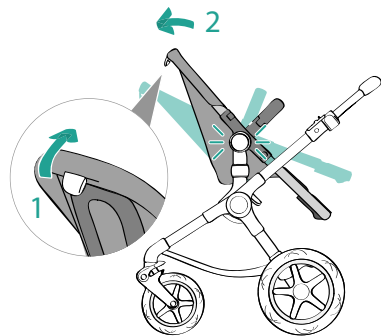

03

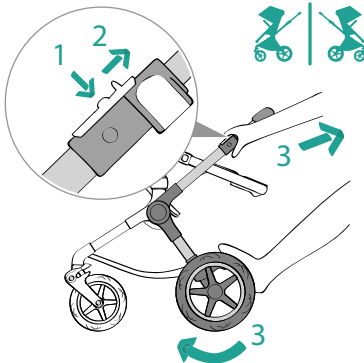

04

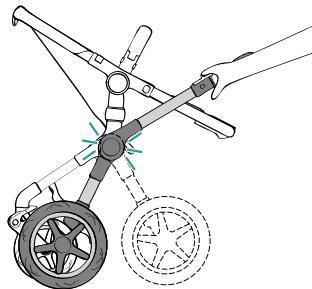

05

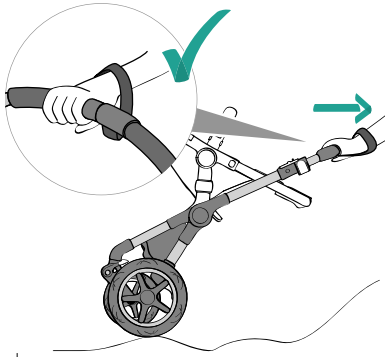

06

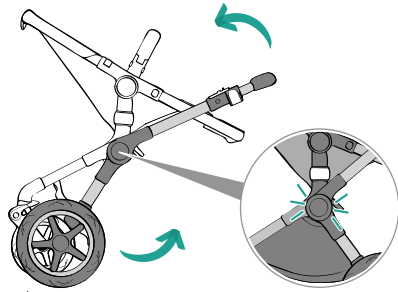

07

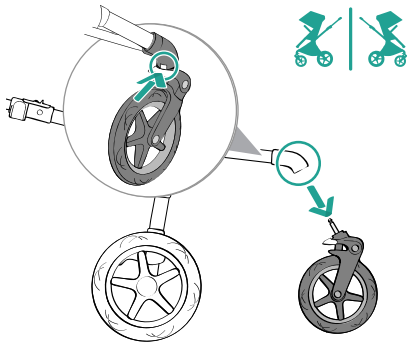

01

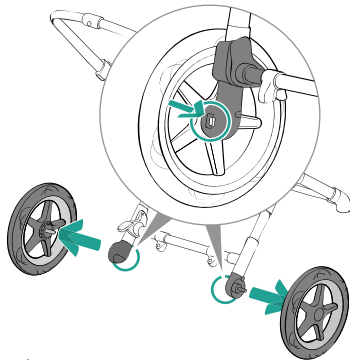

02

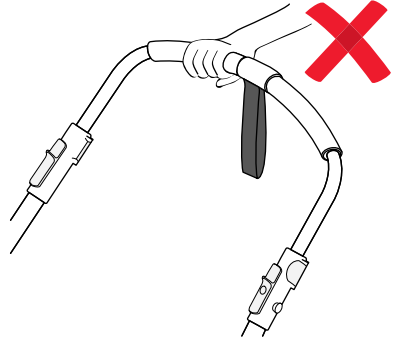
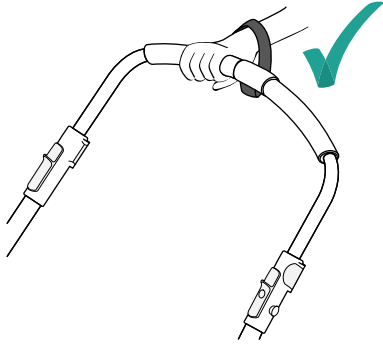

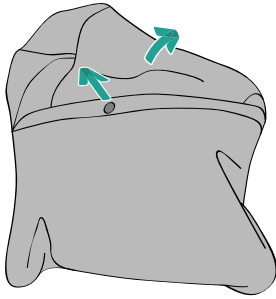

01

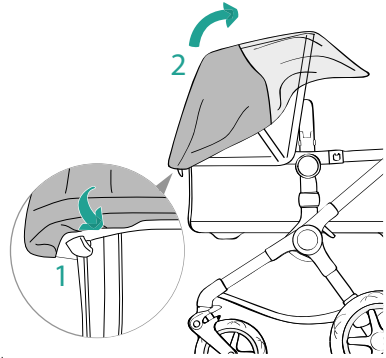

02

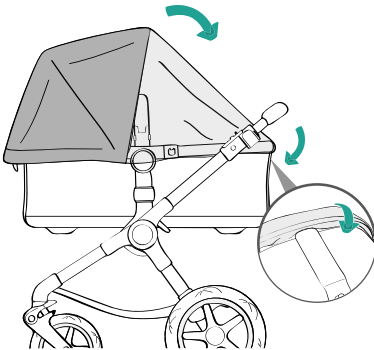

03

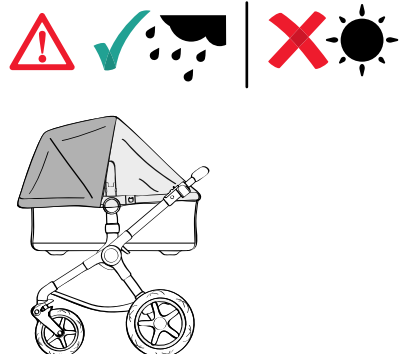
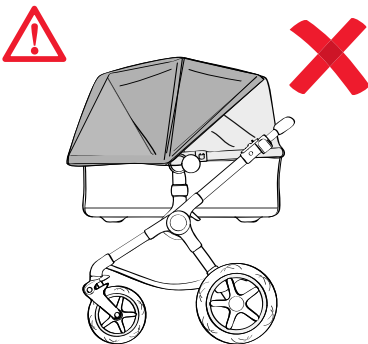
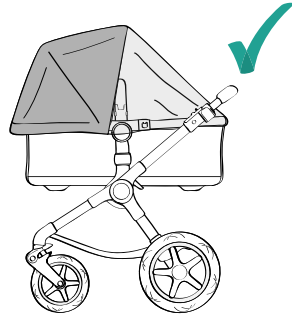

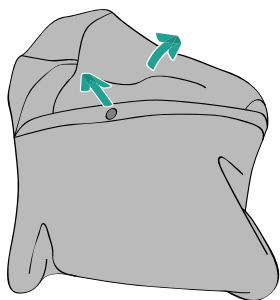

01

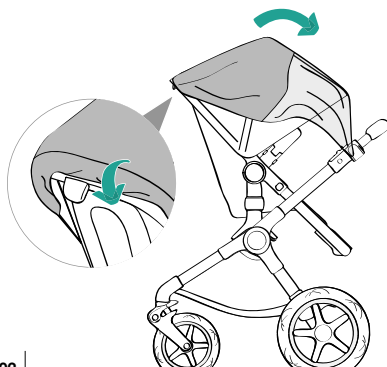

02

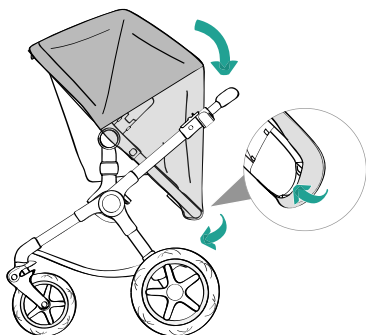

03

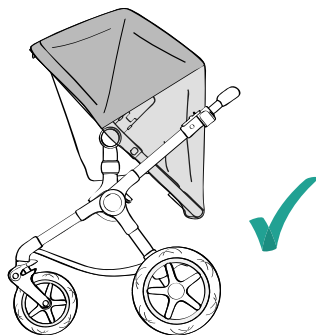

04

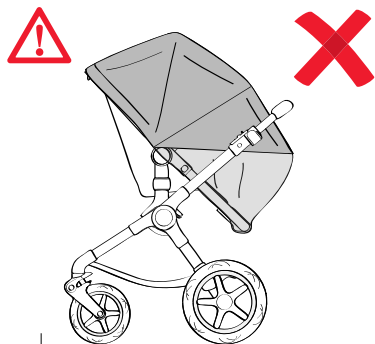

05

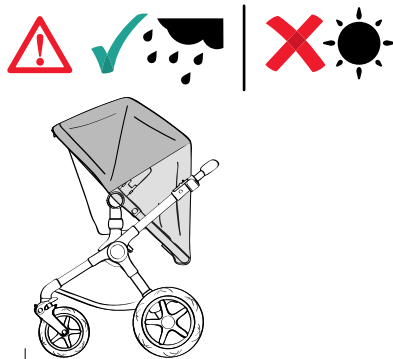

06

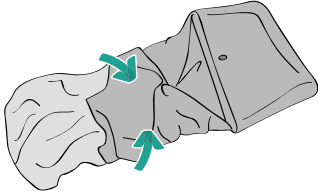

01 |

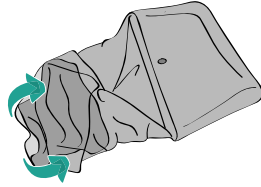

02 |

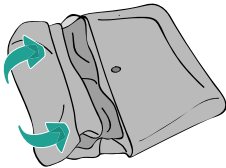

03 |

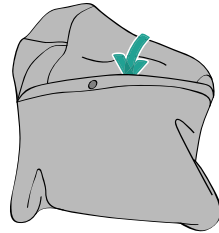

04 |

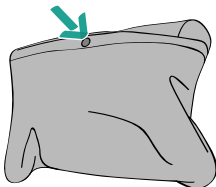

05 |



* For US only

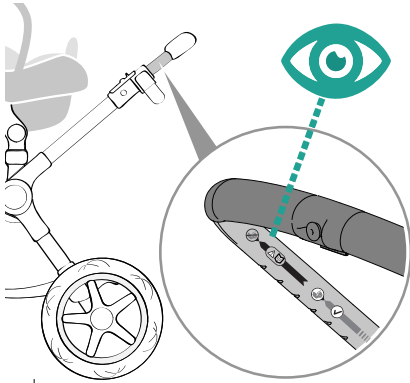

01

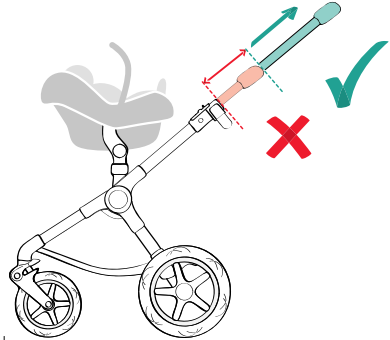

02

The information contained herein is subject to change without notice. Bugaboo International BV shall not be liable for technical errors or omissions contained herein. The purchased product may differ from the product as described in this user guide. Our most recent user guides can be requested at our service departments or at www.bugaboo.com.

© 2019 Bugaboo International BV. BUGABOO, BUGABOO CAMELEON, BUGABOO BEE, BUGABOO DONKEY, BUGABOO FOX, BUGABOO TURTLE, BUGABOO ANT, BUGABOO LYNX and the Bugaboo logos are registered trademarks. The Bugaboo® strollers are patented and design protected.

bugaboo europe & asia

bugaboo international bv
paasheuvelweg 9 a-b
1105 be amsterdam zuidoost
the netherlands

bugaboo americas

bugaboo north america inc.
2150 park place suite 150,
el segundo, ca 90245
united states of america

bugaboo australia

bugaboo australia Pty limited
service department suite 2 level 2
156 edgecliff road woollahra, nsw 2025
australia

bugaboo japan k.k.

東京都渋谷区神宮前
6丁目33-14
神宮ハイツ501
〒150-0001 日本, japan

부가부코리아(유) (bugaboo korea ltd.)

서울특별시, 송파구 오금로 97
방이동, 진넥스빌딩 8층
1577-0680
korea